

REFERENCE SEASTROM WORKMANSHIP STD. 8.4.1.W2

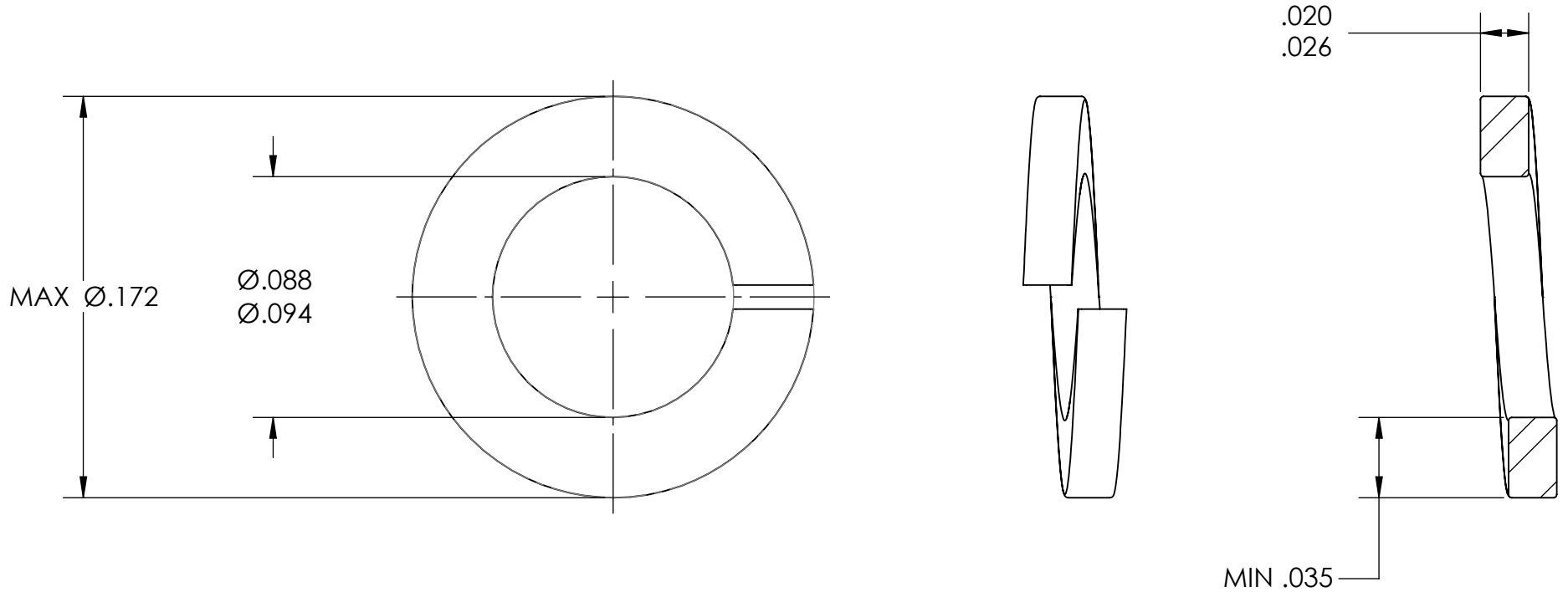

NOTES

1. ZINC PLATE PER ASTM B633, SC1, TYPE III or V, Clear w/Bake
2. SCREW SIZE: 2
3. DIMENSIONS APPLY PRIOR TO PLATING.

PROPRIETARY AND CONFIDENTIAL
 THE INFORMATION CONTAINED IN THIS DRAWING IS THE SOLE PROPERTY OF SEASTROM MANUFACTURING. ANY REPRODUCTION IN PART OR AS A WHOLE WITHOUT THE WRITTEN PERMISSION OF SEASTROM MANUFACTURING IS PROHIBITED.

DIMENSIONS ARE IN INCHES TOLERANCES: FRACTIONAL $\pm 1/32$ ANGULAR: MACH $\pm 1/2$ Deg TWO PLACE DECIMAL $\pm .01$ THREE PLACE DECIMAL $\pm .005$	NAME	DATE	SEASTROM MFG SPRING LOCKWASHER
	DRAWN		
	CHECKED		
	ENG APPR.		
	MFG APPR.		
MATERIAL	COMMENTS:		SIZE A DWG. NO. 5850-9-Z3 REV. -
FINISH			
SEE NOTE 1 DRAWING IS NOT TO SCALE			SHEET 1 OF 1