

REFERENCE SEASTROM WORKMANSHIP STD. 8.4.1.W2

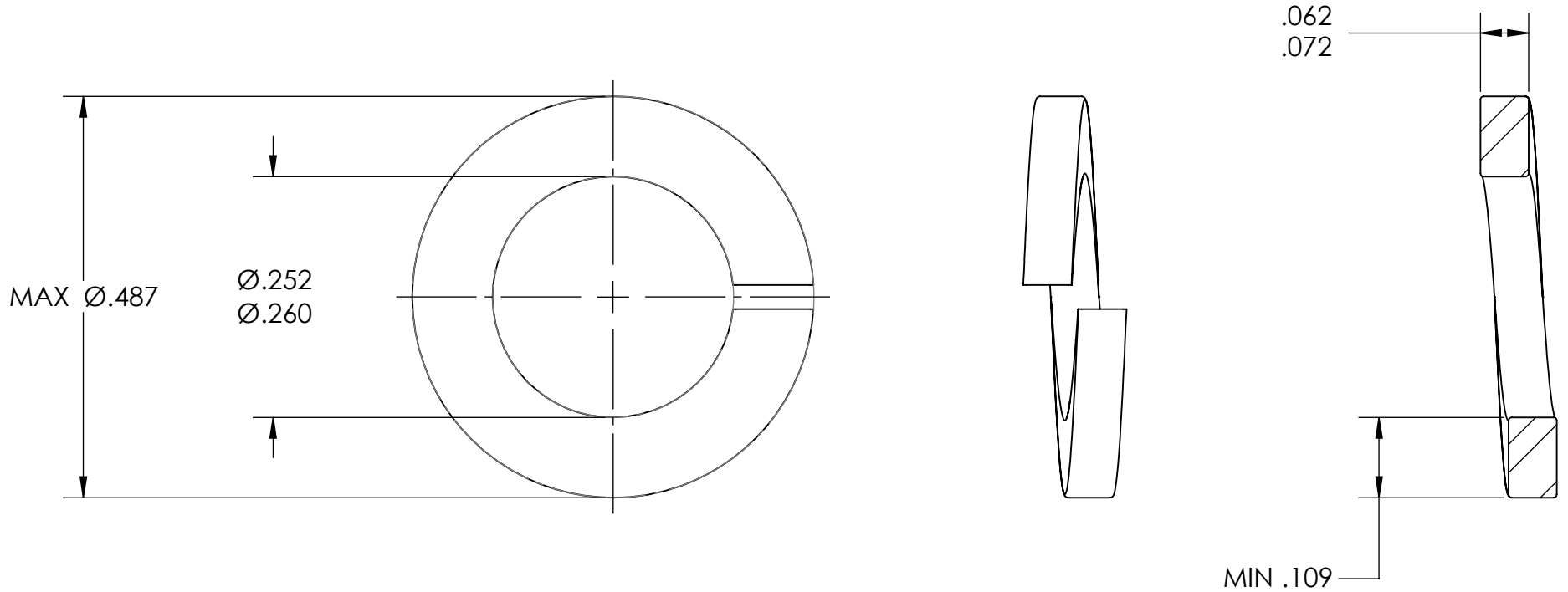

NOTES

1. ZINC PLATE PER ASTM B633, SC1, TYPE II or VI, Yellow w/Bake
2. SCREW SIZE: 1/4
3. DIMENSIONS APPLY PRIOR TO PLATING.

PROPRIETARY AND CONFIDENTIAL
 THE INFORMATION CONTAINED IN THIS DRAWING IS THE SOLE PROPERTY OF SEASTROM MANUFACTURING. ANY REPRODUCTION IN PART OR AS A WHOLE WITHOUT THE WRITTEN PERMISSION OF SEASTROM MANUFACTURING IS PROHIBITED.

| | | | | |
|--|-----------|------|-------------------|-------------------------------|
| DIMENSIONS ARE IN INCHES TOLERANCES: FRACTIONAL $\pm 1/32$ ANGULAR: MACH $\pm 1/2$ Deg TWO PLACE DECIMAL $\pm .01$ THREE PLACE DECIMAL $\pm .005$ | NAME | DATE | SEASTROM MFG | |
| | DRAWN | | | |
| | CHECKED | | SPRING LOCKWASHER | |
| | ENG APPR. | | | |
| | MFG APPR. | | Q.A. | |
| MATERIAL HIGH CARBON SPRING STEEL | COMMENTS: | | SIZE A | DWG. NO. 5850-19-Z2 |
| FINISH SEE NOTE 1 | | | REV. - | |
| DRAWING IS NOT TO SCALE | | | SHEET 1 OF 1 | |