

REFERENCE SEASTROM WORKMANSHIP STD. 8.4.1.W2

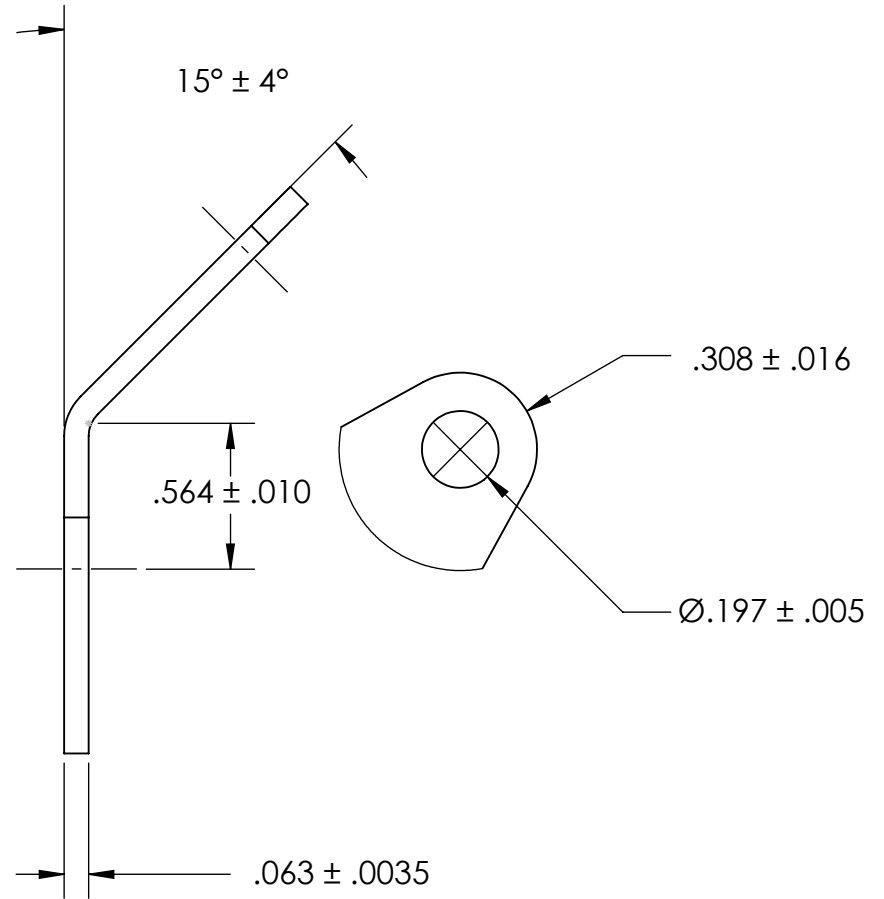
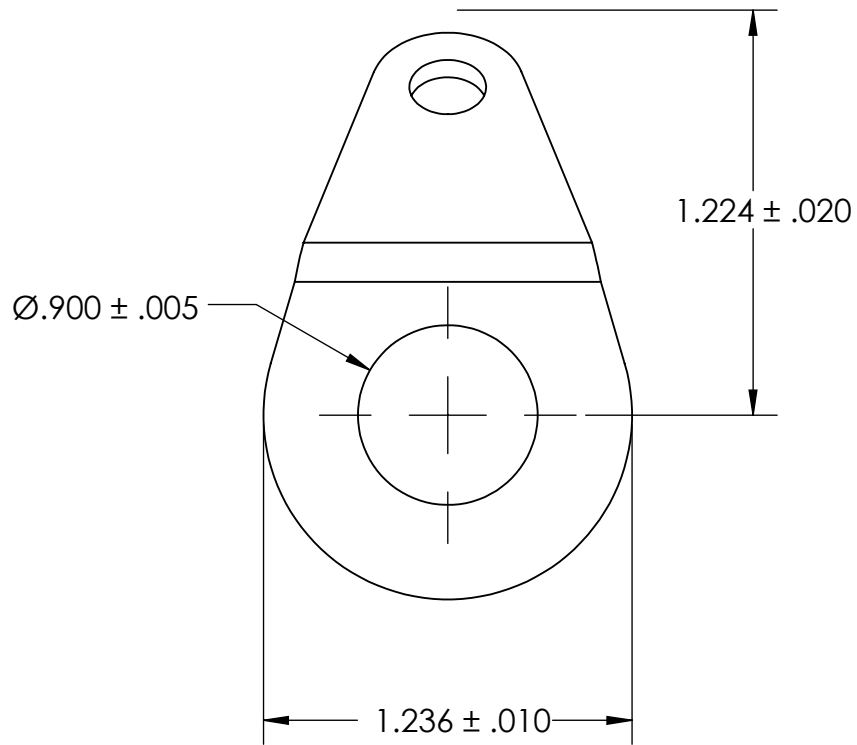

NOTES:
1. NONE

PROPRIETARY AND CONFIDENTIAL
THE INFORMATION CONTAINED IN THIS DRAWING IS THE SOLE PROPERTY OF SEASTROM MANUFACTURING. ANY REPRODUCTION IN PART OR AS A WHOLE WITHOUT THE WRITTEN PERMISSION OF SEASTROM MANUFACTURING IS PROHIBITED.

| | | | |
|--|-----------|------|--------------------------------------|
| DIMENSIONS ARE IN INCHES TOLERANCES: FRACTIONAL ± 1/32 ANGULAR: MACH ± 1/2 Deg TWO PLACE DECIMAL ± .01 THREE PLACE DECIMAL ± .005 | NAME | DATE | SEASTROM MFG RETAINING WASHER |
| | DRAWN | | |
| | CHECKED | | |
| | ENG APPR. | | |
| | MFG APPR. | | |
| MATERIAL | COMMENTS: | | |
| ALUMINUM | | | |
| FINISH | | | |
| SEE NOTE 1 | | | |
| DRAWING IS NOT TO SCALE | | | |
| SIZE A DWG. NO. 5759-26 | | | REV. - |
| | | | SHEET 1 OF 1 |