

REFERENCE SEASTROM WORKMANSHIP STD. 8.4.1.W2

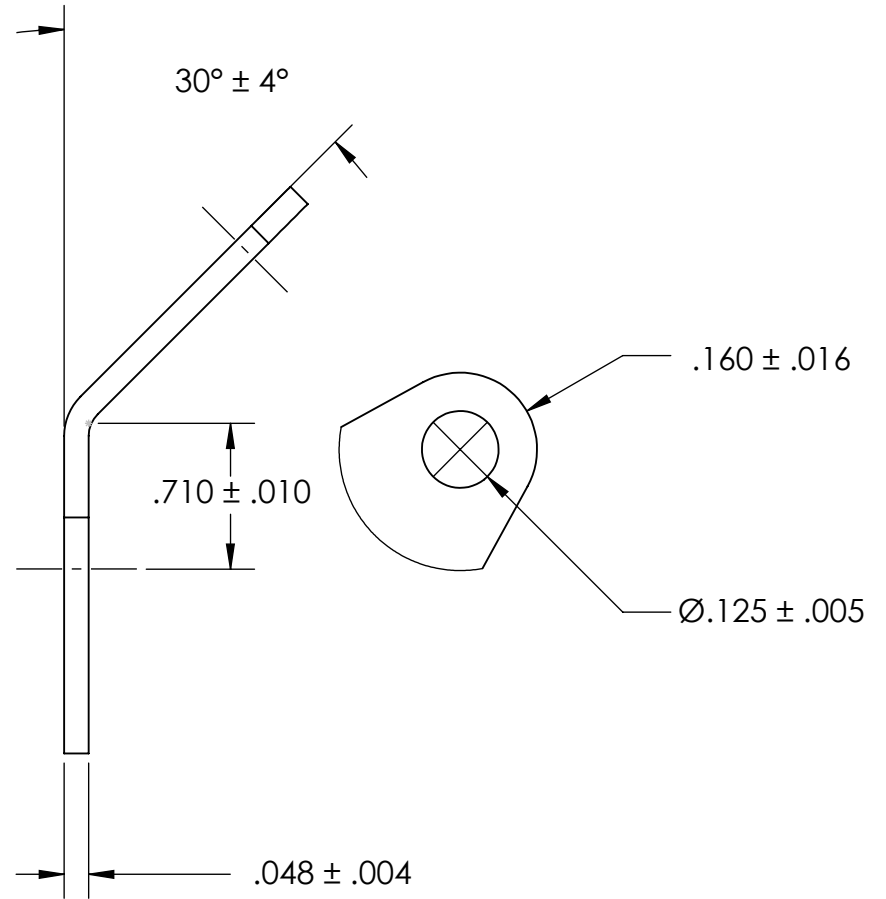
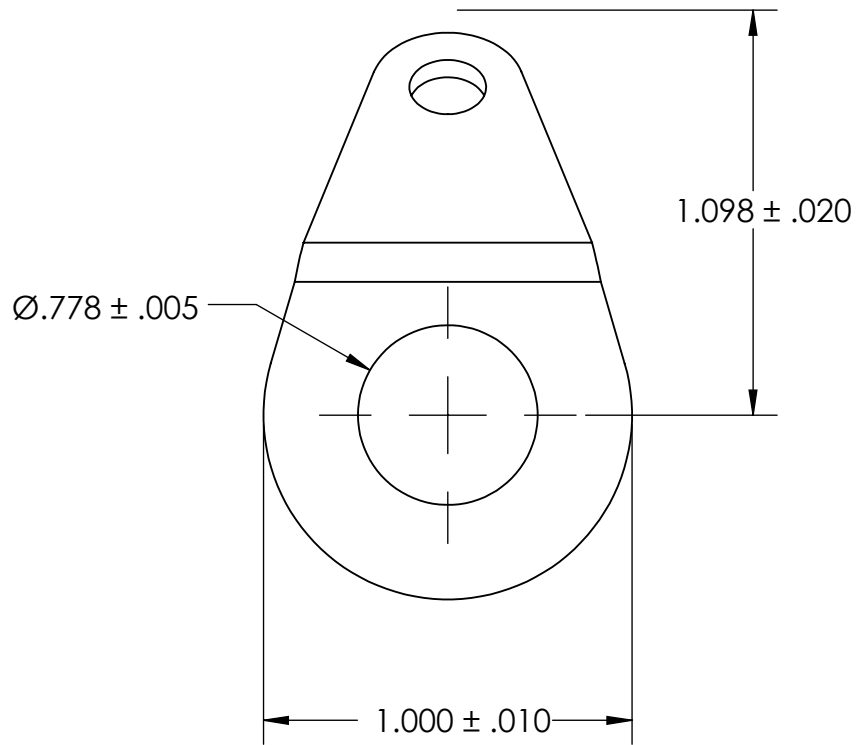

NOTES:  
1. NONE

**PROPRIETARY AND CONFIDENTIAL**  
THE INFORMATION CONTAINED IN THIS DRAWING IS THE SOLE PROPERTY OF SEASTROM MANUFACTURING. ANY REPRODUCTION IN PART OR AS A WHOLE WITHOUT THE WRITTEN PERMISSION OF SEASTROM MANUFACTURING IS PROHIBITED.

|  |           |      |                                      |
|--|-----------|------|--------------------------------------|
| DIMENSIONS ARE IN INCHES<br>TOLERANCES:<br>FRACTIONAL ± 1/32<br>ANGULAR: MACH ± 1/2 Deg<br>TWO PLACE DECIMAL ± .01<br>THREE PLACE DECIMAL ± .005 | NAME      | DATE | SEASTROM MFG<br><br>RETAINING WASHER |
|  | DRAWN     |      |                                      |
|  | CHECKED   |      |                                      |
|  | ENG APPR. |      |                                      |
|  | MFG APPR. |      |                                      |
|  | Q.A.      |      |                                      |
| MATERIAL   | COMMENTS: |      |                                      |
| 300 SERIES STAINLESS   |           |      |                                      |
| FINISH   |           |      |                                      |
| SEE NOTE 1   |           |      |                                      |
| DRAWING IS NOT TO SCALE  |           |      |                                      |
| SIZE   | DWG. NO.  | REV. |                                      |
| A  | 5759-23   | -    |                                      |