

REFERENCE SEASTROM WORKMANSHIP STD. 8.4.1.W2

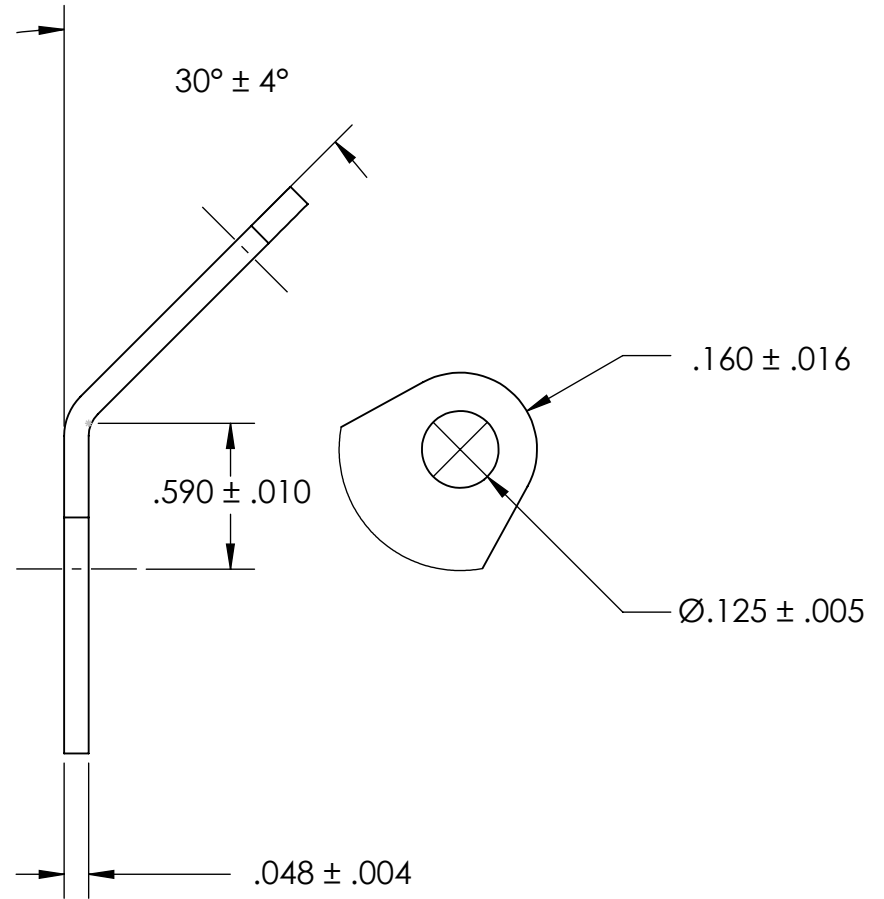
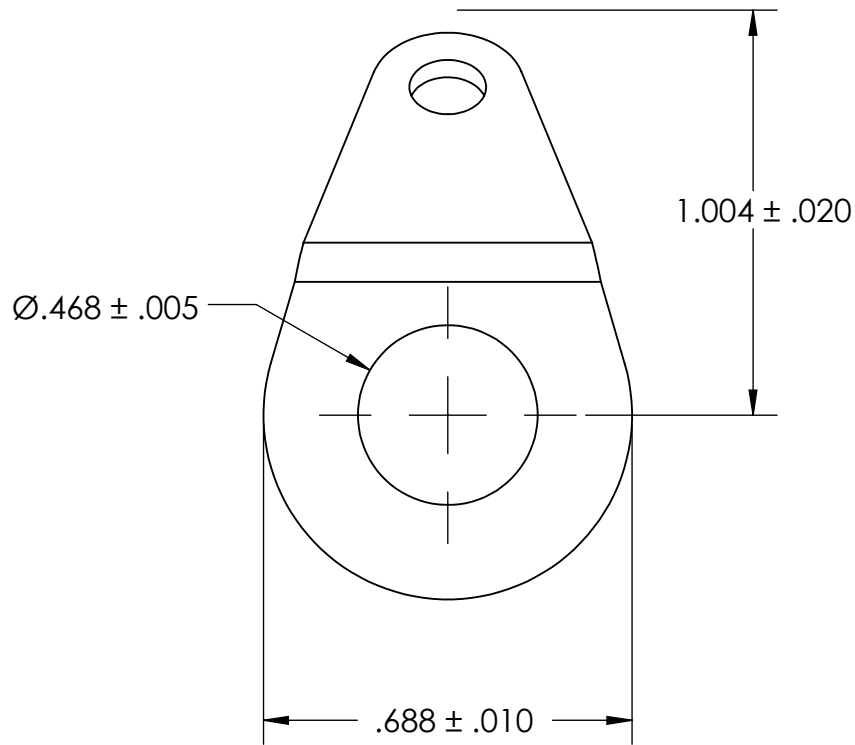

NOTES:

1. PASSIVATE PER AMS2700 METHOD 1 TYPE 2 CLASS 1
2. DIMENSIONS APPLY PRIOR TO PLATING.

PROPRIETARY AND CONFIDENTIAL
 THE INFORMATION CONTAINED IN THIS DRAWING IS THE SOLE PROPERTY OF SEASTROM MANUFACTURING. ANY REPRODUCTION IN PART OR AS A WHOLE WITHOUT THE WRITTEN PERMISSION OF SEASTROM MANUFACTURING IS PROHIBITED.

DIMENSIONS ARE IN INCHES TOLERANCES: FRACTIONAL ± 1/32 ANGULAR: MACH ± 1/2 Deg TWO PLACE DECIMAL ± .01 THREE PLACE DECIMAL ± .005	NAME	DATE	SEASTROM MFG RETAINING WASHER
	DRAWN		
	CHECKED		
	ENG APPR.		
	MFG APPR.		
MATERIAL	COMMENTS:		
300 SERIES STAINLESS			
FINISH			
SEE NOTE 1			
DRAWING IS NOT TO SCALE			
SIZE A		DWG. NO. 5759-17-P	REV. -
			SHEET 1 OF 1