

REFERENCE SEASTROM WORKMANSHIP STD. 8.4.1.W2

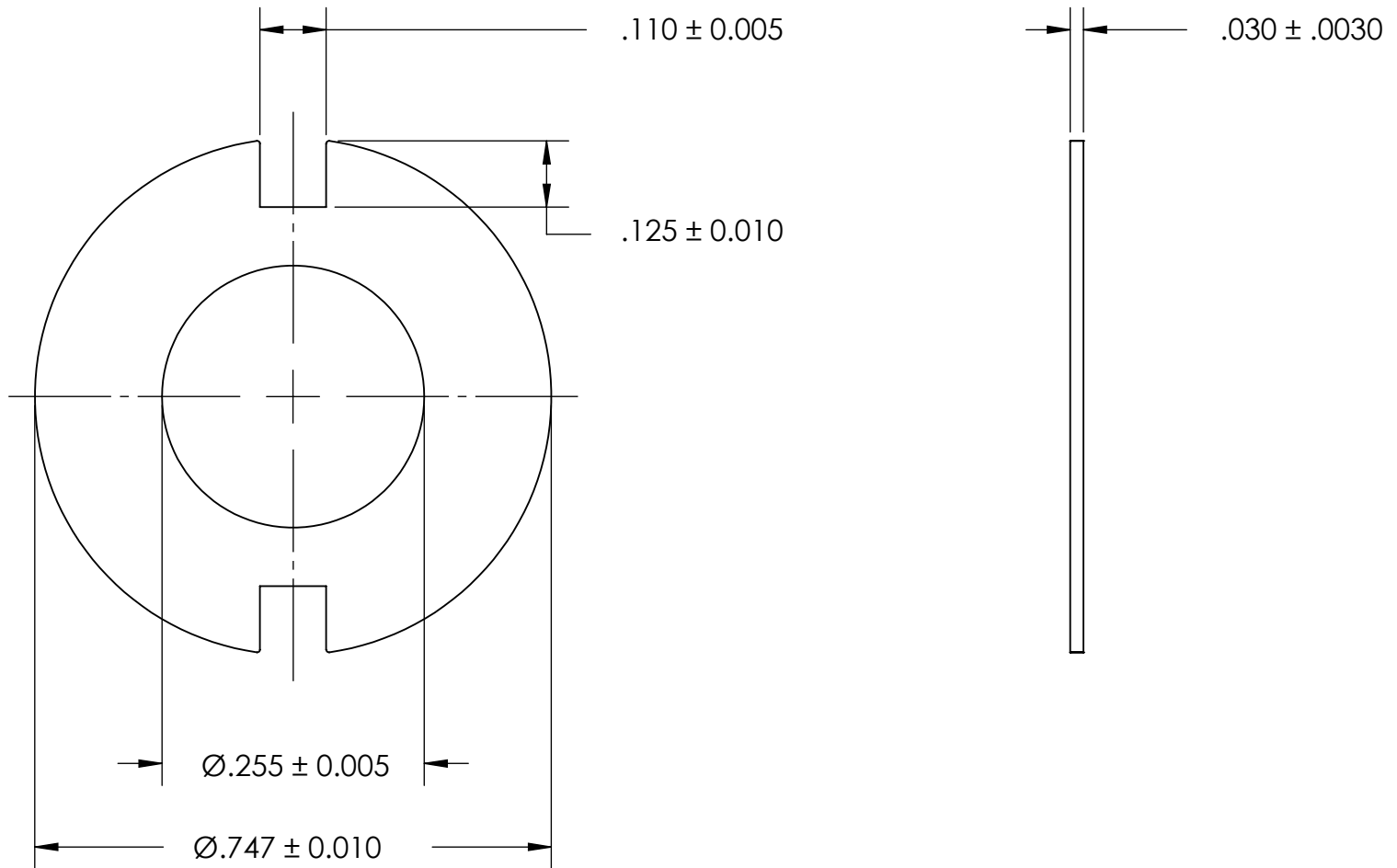

NOTES:
1. NONE

PROPRIETARY AND CONFIDENTIAL
THE INFORMATION CONTAINED IN THIS DRAWING IS THE SOLE PROPERTY OF SEASTROM MANUFACTURING. ANY REPRODUCTION IN PART OR AS A WHOLE WITHOUT THE WRITTEN PERMISSION OF SEASTROM MANUFACTURING IS PROHIBITED.

DIMENSIONS ARE IN INCHES TOLERANCES: FRACTIONAL ± 1/32 ANGULAR: MACH ± 1/2 Deg TWO PLACE DECIMAL ± .01 THREE PLACE DECIMAL ± .005		NAME	DATE	SEASTROM MFG EXTERNAL NOTCH WASHER
	DRAWN			
	CHECKED			
	ENG APPR.			
	MFG APPR.			
MATERIAL	COMMENTS:			
COLD ROLLED STEEL				
FINISH				
SEE NOTE 1				
DRAWING IS NOT TO SCALE	SIZE	DWG. NO.	REV.	
	A	5754-8	-	
				SHEET 1 OF 1