

REFERENCE SEASTROM WORKMANSHIP STD. 8.4.1.W2

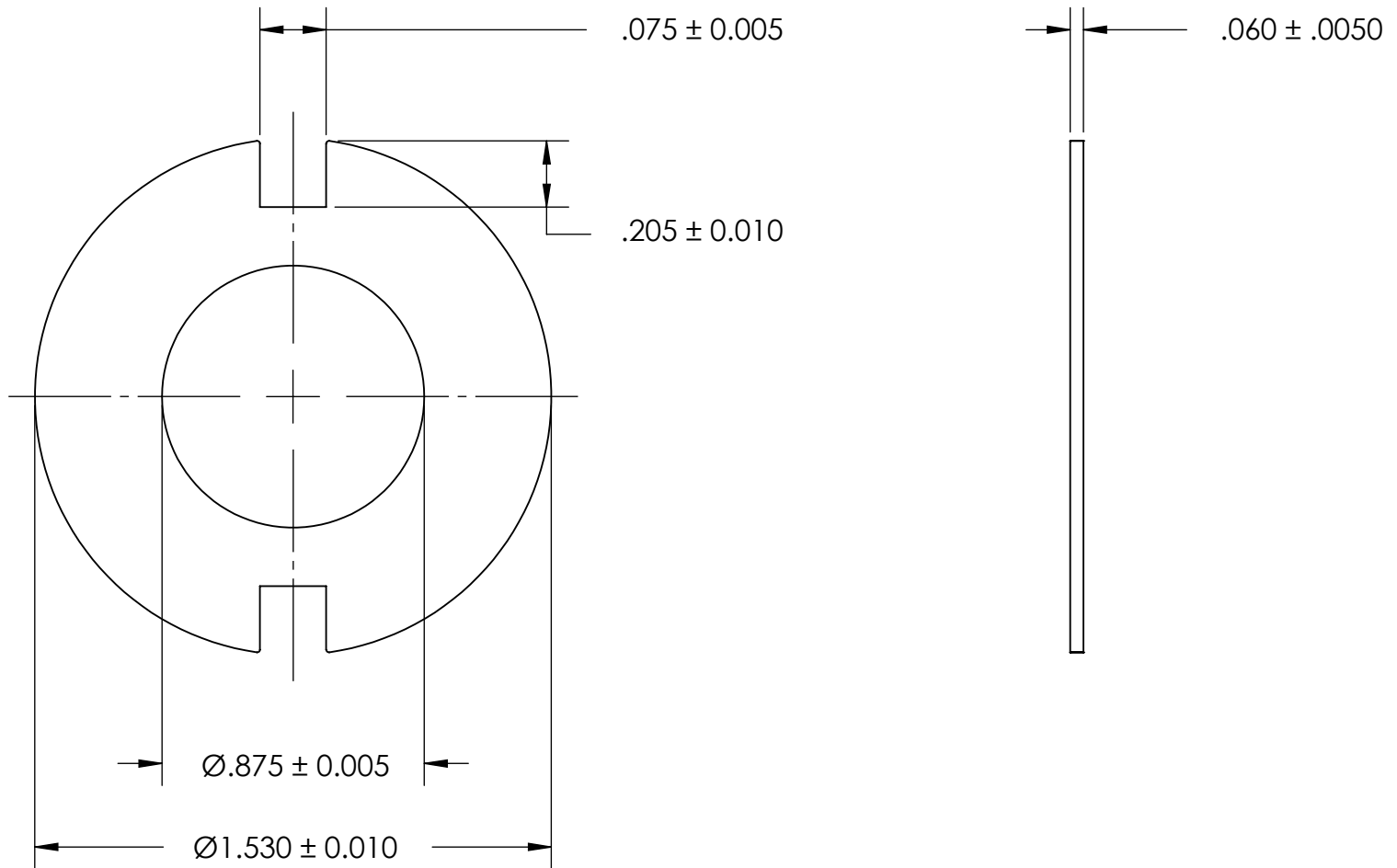

NOTES:
1. NONE

PROPRIETARY AND CONFIDENTIAL
THE INFORMATION CONTAINED IN THIS DRAWING IS THE SOLE PROPERTY OF SEASTROM MANUFACTURING. ANY REPRODUCTION IN PART OR AS A WHOLE WITHOUT THE WRITTEN PERMISSION OF SEASTROM MANUFACTURING IS PROHIBITED.

DIMENSIONS ARE IN INCHES TOLERANCES: FRACTIONAL $\pm 1/32$ ANGULAR: MACH $\pm 1/2$ Deg TWO PLACE DECIMAL $\pm .01$ THREE PLACE DECIMAL $\pm .005$		NAME	DATE	SEASTROM MFG
	DRAWN			
	CHECKED			
	ENG APPR.			
	MFG APPR.			
MATERIAL	Q.A.			
FINISH	COMMENTS:			
SEE NOTE 1				
DRAWING IS NOT TO SCALE	SIZE	DWG. NO.	REV.	
	A	5754-16	-	
				SHEET 1 OF 1