

REFERENCE SEASTROM WORKMANSHIP STD. 8.4.1.W2

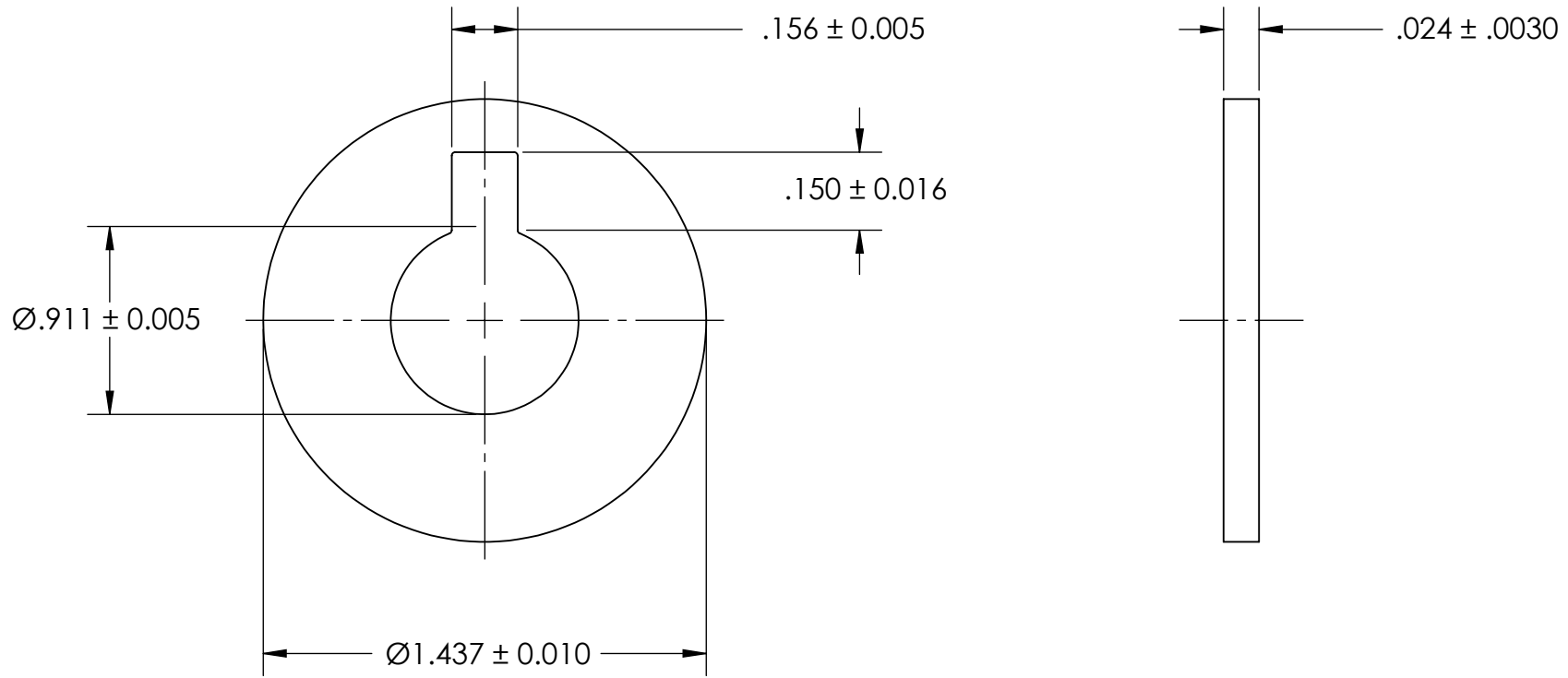

NOTES:

1. NONE

PROPRIETARY AND CONFIDENTIAL

THE INFORMATION CONTAINED IN THIS DRAWING IS THE SOLE PROPERTY OF SEASTROM MANUFACTURING. ANY REPRODUCTION IN PART OR AS A WHOLE WITHOUT THE WRITTEN PERMISSION OF SEASTROM MANUFACTURING IS PROHIBITED.

DIMENSIONS ARE IN INCHES TOLERANCES: FRACTIONAL $\pm 1/32$ ANGULAR: MACH $\pm 1/2$ Deg TWO PLACE DECIMAL $\pm .01$ THREE PLACE DECIMAL $\pm .005$	NAME	DATE	SEASTROM MFG		
	DRAWN				
	CHECKED		INTERNAL NOTCH WASHER		
	ENG APPR.				
	MFG APPR.				
	Q.A.				
MATERIAL	COMMENTS:		SIZE	DWG. NO.	REV.
COLD ROLLED STEEL			A	5750-20	-
FINISH			SHEET 1 OF 1		
SEE NOTE 1					
DRAWING IS NOT TO SCALE					