

REFERENCE SEASTROM WORKMANSHIP STD. 8.4.1.W2

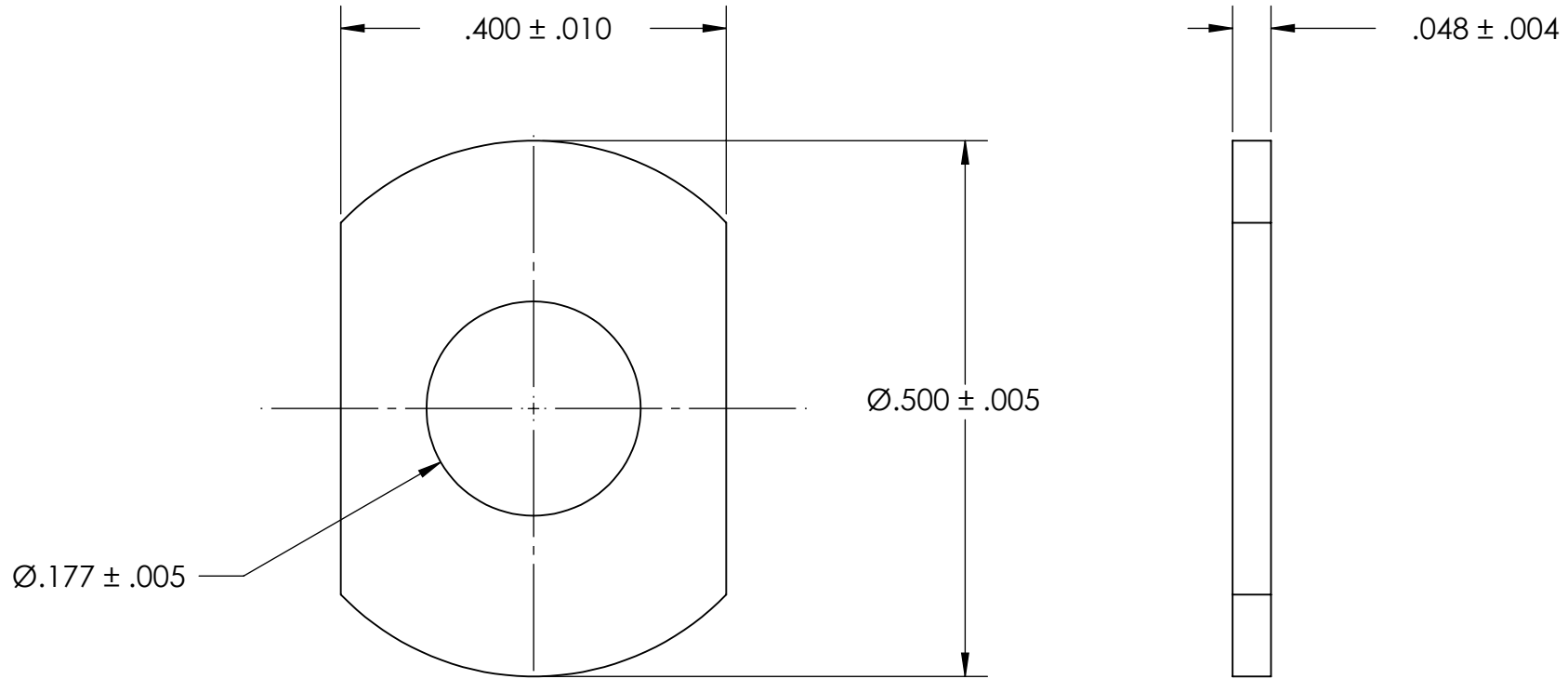

NOTES  
1. NONE

2. SCREW SIZE: 8

**PROPRIETARY AND CONFIDENTIAL**  
THE INFORMATION CONTAINED IN THIS DRAWING IS THE SOLE PROPERTY OF SEASTROM MANUFACTURING. ANY REPRODUCTION IN PART OR AS A WHOLE WITHOUT THE WRITTEN PERMISSION OF SEASTROM MANUFACTURING IS PROHIBITED.

DIMENSIONS ARE IN INCHES TOLERANCES: FRACTIONAL $\pm 1/32$ ANGULAR: MACH $\pm 1/2$ Deg TWO PLACE DECIMAL $\pm .01$ THREE PLACE DECIMAL $\pm .005$		NAME	DATE	SEASTROM MFG
MATERIAL COLD ROLLED STEEL	FINISH SEE NOTE 1	DRAWN	CHECKED	
DRAWING IS NOT TO SCALE		ENG APPR.	MFG APPR.	REV. -
		Q.A.	COMMENTS:	
SIZE A	DWG. NO. 5738-4			SHEET 1 OF 1