

SCREW SIZE # 4

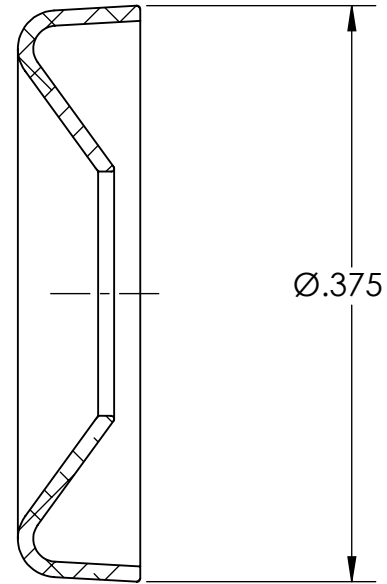
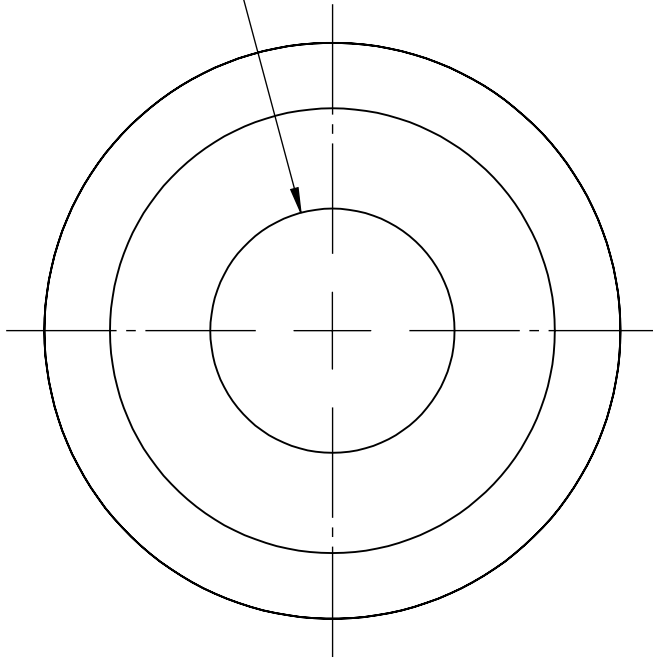

NOTES:

- 1. NONE

PROPRIETARY AND CONFIDENTIAL
 THE INFORMATION CONTAINED IN THIS DRAWING IS THE SOLE PROPERTY OF SEASTROM MANUFACTURING. ANY REPRODUCTION IN PART OR AS A WHOLE WITHOUT THE WRITTEN PERMISSION OF SEASTROM MANUFACTURING IS PROHIBITED.

DIMENSIONS ARE IN INCHES TOLERANCES: FRACTIONAL $\pm 1/32$ ANGULAR: MACH $\pm 1/2$ Deg TWO PLACE DECIMAL $\pm .01$ THREE PLACE DECIMAL $\pm .005$		NAME	DATE	SEASTROM MFG		
MATERIAL	300 SERIES STAINLESS	DRAWN				COUNTERSUNK WASHER
FINISH	SEE NOTE 1	CHECKED		SIZE	DWG. NO.	
DRAWING IS NOT TO SCALE		ENG APPR.		A	5725-4-SS	-
		MFG APPR.		SHEET 1 OF 1		
		Q.A.				
		COMMENTS:				