

SCREW SIZE # 10

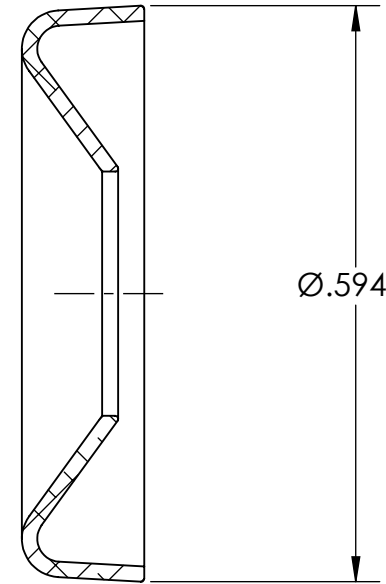
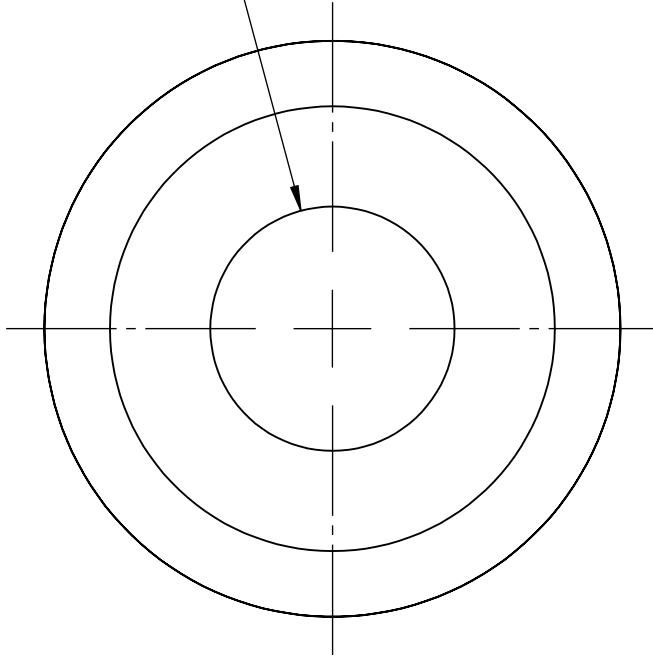

NOTES:

1. NICKEL PLATE PER AMS QQ-N-290 CLASS 1 GRADE G
2. DIMENSIONS APPLY PRIOR TO PLATING.

PROPRIETARY AND CONFIDENTIAL
 THE INFORMATION CONTAINED IN THIS DRAWING IS THE SOLE PROPERTY OF SEASTROM MANUFACTURING. ANY REPRODUCTION IN PART OR AS A WHOLE WITHOUT THE WRITTEN PERMISSION OF SEASTROM MANUFACTURING IS PROHIBITED.

DIMENSIONS ARE IN INCHES TOLERANCES: FRACTIONAL $\pm 1/32$ ANGULAR: MACH $\pm 1/2$ Deg TWO PLACE DECIMAL $\pm .01$ THREE PLACE DECIMAL $\pm .005$		NAME	DATE	SEASTROM MFG COUNTERSUNK WASHER
	DRAWN			
	CHECKED			
	ENG APPR.			
	MFG APPR.			
MATERIAL BRASS	Q.A.			SIZE A DWG. NO. 5725-10 REV. -
FINISH SEE NOTE 1	COMMENTS:			
DRAWING IS NOT TO SCALE				SHEET 1 OF 1