

SCREW SIZE # 10

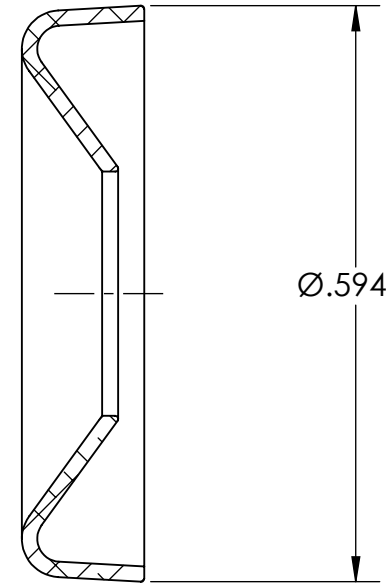
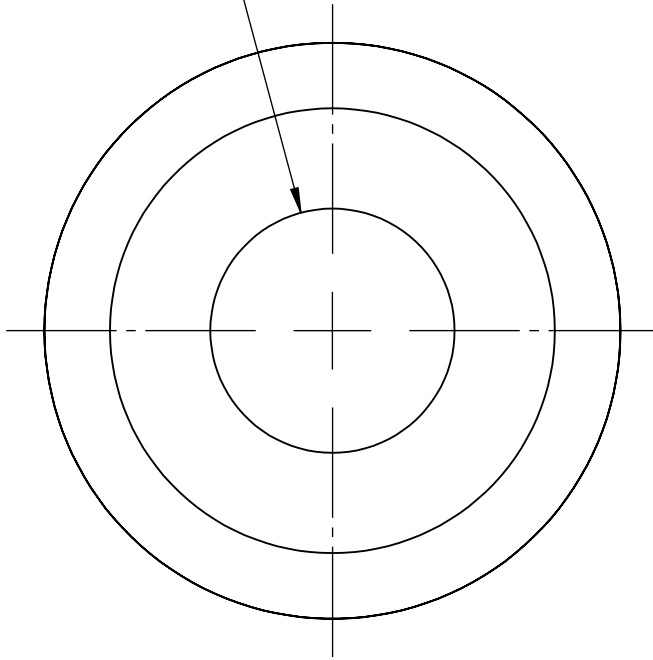

NOTES:

- 1. NONE

**PROPRIETARY AND CONFIDENTIAL**  
 THE INFORMATION CONTAINED IN THIS DRAWING IS THE SOLE PROPERTY OF SEASTROM MANUFACTURING. ANY REPRODUCTION IN PART OR AS A WHOLE WITHOUT THE WRITTEN PERMISSION OF SEASTROM MANUFACTURING IS PROHIBITED.

DIMENSIONS ARE IN INCHES TOLERANCES: FRACTIONAL $\pm 1/32$ ANGULAR: MACH $\pm 1/2$ Deg TWO PLACE DECIMAL $\pm .01$ THREE PLACE DECIMAL $\pm .005$		NAME	DATE	SEASTROM MFG
MATERIAL	FINISH	DRAWN	CHECKED	
300 SERIES STAINLESS	SEE NOTE 1	ENG APPR.	MFG APPR.	
DRAWING IS NOT TO SCALE		Q.A.	COMMENTS:	
SIZE	DWG. NO.	REV.		
A	5725-10-SS	-	SHEET 1 OF 1	