

REFERENCE SEASTROM WORKMANSHIP STD. 8.4.1.W2

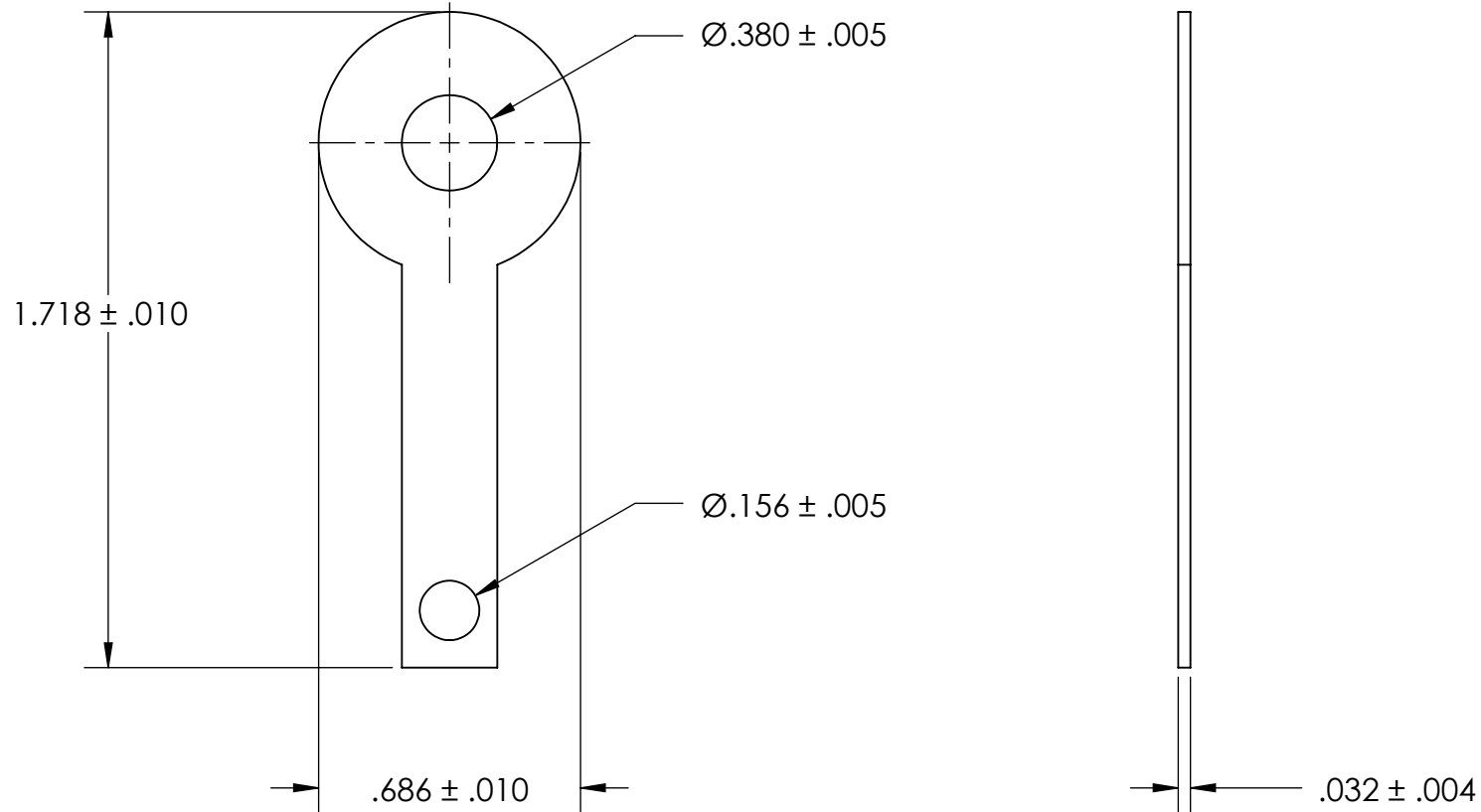

NOTES

1. BRIGHT TIN PLATE PER ASTM B545, CLASS B
2. SCREW SIZE: -
3. DIMENSIONS APPLY PRIOR TO PLATING.

PROPRIETARY AND CONFIDENTIAL
 THE INFORMATION CONTAINED IN THIS DRAWING IS THE SOLE PROPERTY OF SEASTROM MANUFACTURING. ANY REPRODUCTION IN PART OR AS A WHOLE WITHOUT THE WRITTEN PERMISSION OF SEASTROM MANUFACTURING IS PROHIBITED.

| | | | | | |
|--|-----------|------|--------------|----------|------|
| DIMENSIONS ARE IN INCHES TOLERANCES: FRACTIONAL $\pm 1/32$ ANGULAR: MACH $\pm 1/2$ Deg TWO PLACE DECIMAL $\pm .01$ THREE PLACE DECIMAL $\pm .005$ | NAME | DATE | SEASTROM MFG | | |
| | DRAWN | | | | |
| | CHECKED | | SOLDER LUG | | |
| | ENG APPR. | | | | |
| | MFG APPR. | | | | |
| MATERIAL | Q.A. | | SIZE | DWG. NO. | REV. |
| BRASS, HALF HARD | COMMENTS: | | A | 5433-4 | - |
| FINISH | | | SHEET 1 OF 1 | | |
| SEE NOTE 1 | | | | | |
| DRAWING IS NOT TO SCALE | | | | | |