

REFERENCE SEASTROM WORKMANSHIP STD. 8.4.1.W2

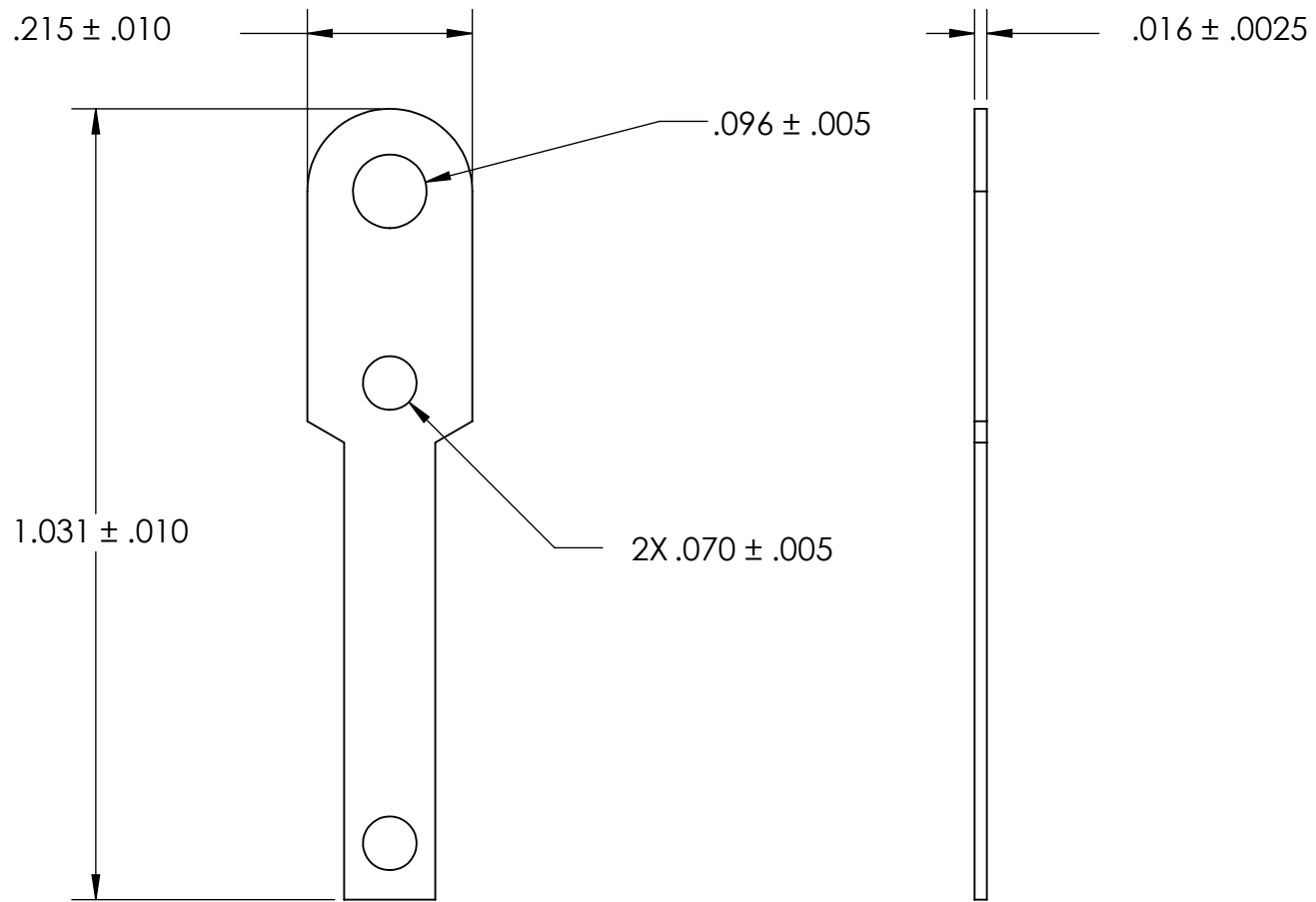

STYLE 1

NOTES

1. SILVER PLATE PER ASTM B700 TYPE 1 GRADE A CLASS S, 2.5µm TH w/NICKEL UNDERPLATE
2. SCREW SIZE: 2
3. DIMENSIONS APPLY PRIOR TO PLATING.

PROPRIETARY AND CONFIDENTIAL
 THE INFORMATION CONTAINED IN THIS DRAWING IS THE SOLE PROPERTY OF SEASTROM MANUFACTURING. ANY REPRODUCTION IN PART OR AS A WHOLE WITHOUT THE WRITTEN PERMISSION OF SEASTROM MANUFACTURING IS PROHIBITED.

DIMENSIONS ARE IN INCHES TOLERANCES: FRACTIONAL ± 1/32 ANGULAR: MACH ± 1/2 Deg TWO PLACE DECIMAL ± .01 THREE PLACE DECIMAL ± .005	NAME	DATE	SEASTROM MFG		
	DRAWN				
	CHECKED		SOLDER LUG		
	ENG APPR.				
	MFG APPR.				
MATERIAL	COMMENTS:		SIZE	DWG. NO.	REV.
BRASS, HALF HARD			A	5424-1-S	-
FINISH					
SEE NOTE 1					
DRAWING IS NOT TO SCALE			SHEET 1 OF 1		