

REFERENCE SEASTROM WORKMANSHIP STD. 8.4.1.W2

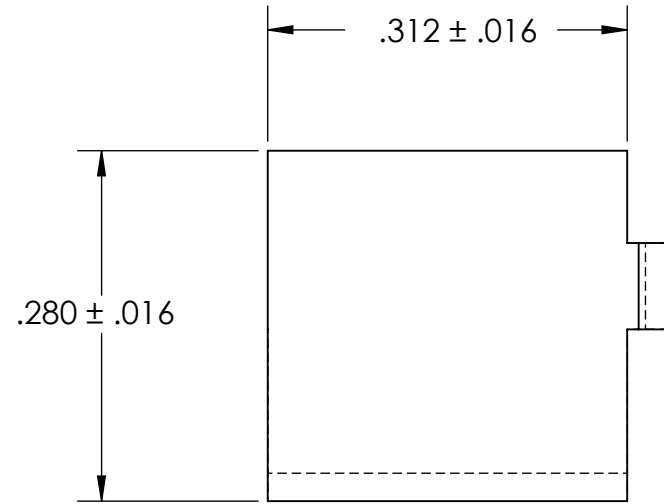
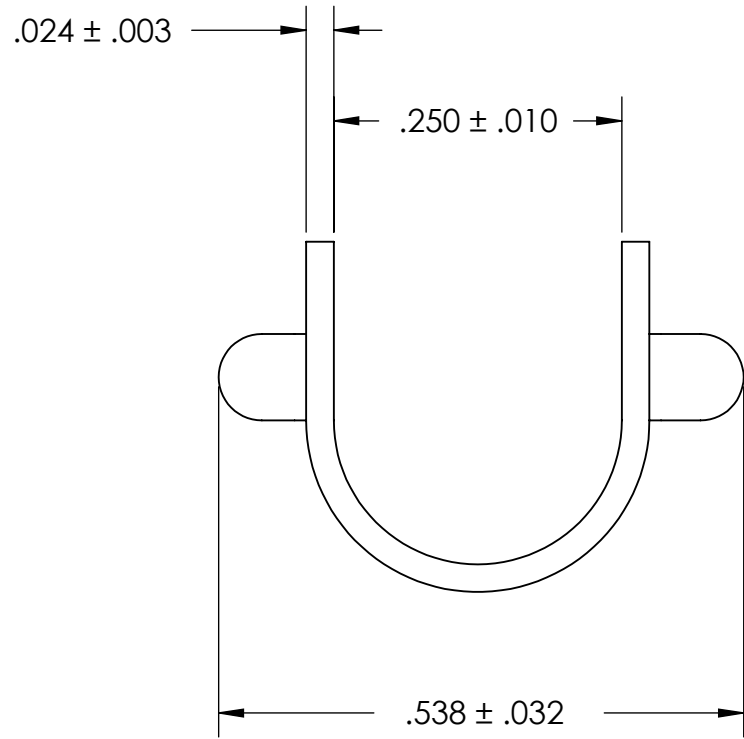

NOTES

1. ZINC PLATE PER ASTM B633, SC1, TYPE III or V, Clear
2. DIMENSIONS APPLY PRIOR TO PLATING.

PROPRIETARY AND CONFIDENTIAL
 THE INFORMATION CONTAINED IN THIS DRAWING IS THE SOLE PROPERTY OF SEASTROM MANUFACTURING. ANY REPRODUCTION IN PART OR AS A WHOLE WITHOUT THE WRITTEN PERMISSION OF SEASTROM MANUFACTURING IS PROHIBITED.

DIMENSIONS ARE IN INCHES TOLERANCES: FRACTIONAL $\pm 1/32$ ANGULAR: MACH $\pm 1/2$ Deg TWO PLACE DECIMAL $\pm .01$ THREE PLACE DECIMAL $\pm .005$	NAME	DATE	SEASTROM MFG
	DRAWN		
	CHECKED		
	ENG APPR.		
	MFG APPR.		
MATERIAL	COMMENTS:		SIZE
COLD ROLLED STEEL			DWG. NO.
FINISH			REV.
SEE NOTE 1			A
DRAWING IS NOT TO SCALE			5358-1
			-
			SHEET 1 OF 1