

REFERENCE SEASTROM WORKMANSHIP STD. 8.4.1.W2

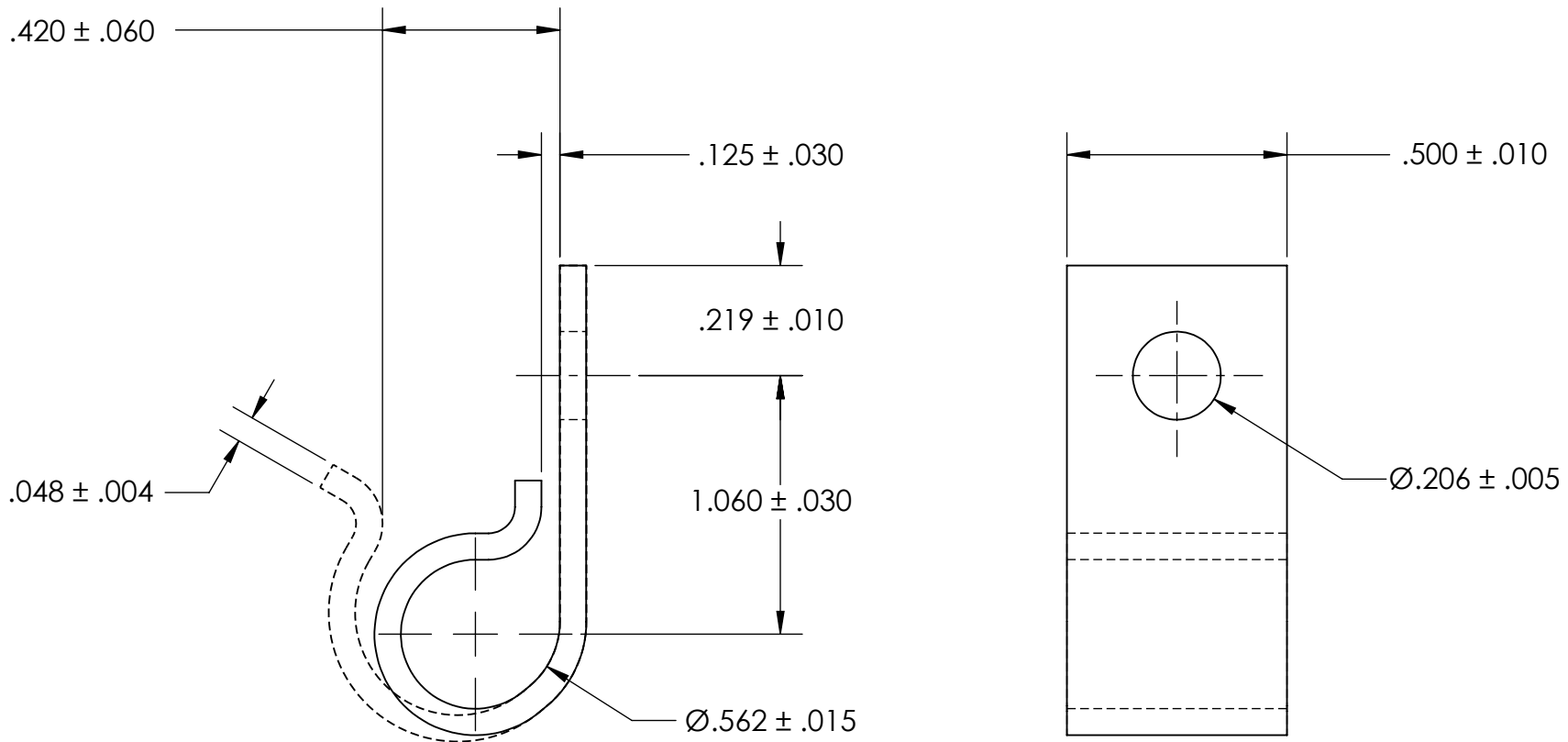

NOTES

1. ZINC PLATE PER ASTM B633, SC1, TYPE III or V, Clear
2. DIMENSIONS APPLY PRIOR TO PLATING.

PROPRIETARY AND CONFIDENTIAL
 THE INFORMATION CONTAINED IN THIS DRAWING IS THE SOLE PROPERTY OF SEASTROM MANUFACTURING. ANY REPRODUCTION IN PART OR AS A WHOLE WITHOUT THE WRITTEN PERMISSION OF SEASTROM MANUFACTURING IS PROHIBITED.

| | | | | |
|--|-----------|------|--------------|-----------|
| DIMENSIONS ARE IN INCHES TOLERANCES: FRACTIONAL ± 1/32 ANGULAR: MACH ± 1/2 Deg TWO PLACE DECIMAL ± .01 THREE PLACE DECIMAL ± .005 | NAME | DATE | SEASTROM MFG | |
| | DRAWN | | | |
| | CHECKED | | J CLIP | |
| | ENG APPR. | | | |
| | MFG APPR. | | | |
| MATERIAL | COMMENTS: | | SIZE | DWG. NO. |
| COLD ROLLED STEEL | | | A | 5318-56-2 |
| FINISH | | | REV. | |
| SEE NOTE 1 | | | - | |
| DRAWING IS NOT TO SCALE | | | SHEET 1 OF 1 | |