

STYLE 1

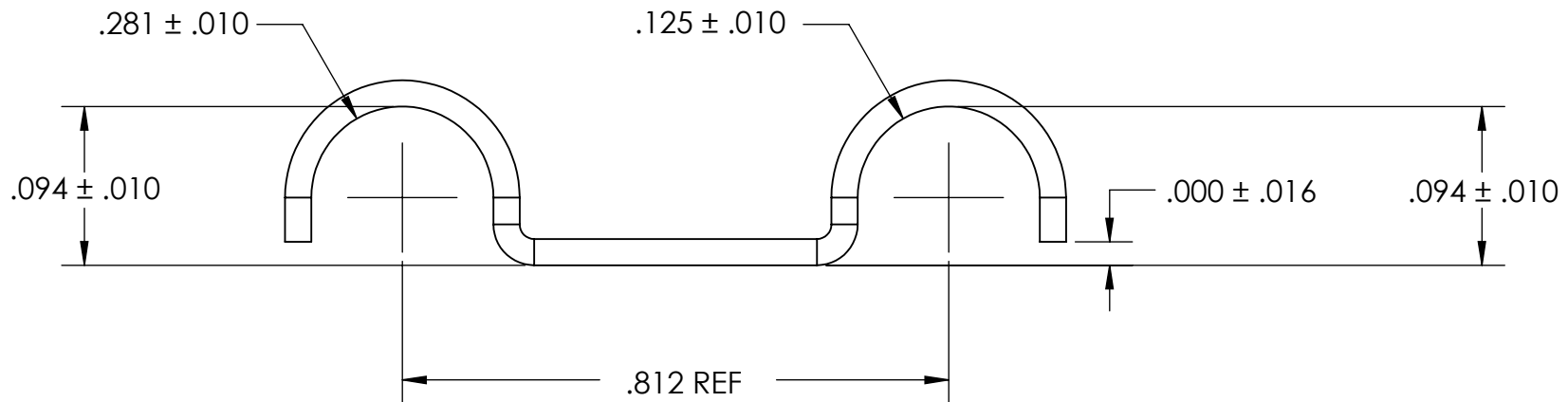

NOTES
1. NONE

PROPRIETARY AND CONFIDENTIAL
THE INFORMATION CONTAINED IN THIS DRAWING IS THE SOLE PROPERTY OF SEASTROM MANUFACTURING. ANY REPRODUCTION IN PART OR AS A WHOLE WITHOUT THE WRITTEN PERMISSION OF SEASTROM MANUFACTURING IS PROHIBITED.

DIMENSIONS ARE IN INCHES TOLERANCES: FRACTIONAL ± 1/32 ANGULAR: MACH ± 1/2 Deg TWO PLACE DECIMAL ± .01 THREE PLACE DECIMAL ± .005		NAME	DATE	SEASTROM MFG
MATERIAL COLD ROLLED STEEL	FINISH SEE NOTE 1	DRAWN	CHECKED	
DRAWING IS NOT TO SCALE		ENG APPR.	MFG APPR.	REV. -
		Q.A.	COMMENTS:	
SIZE A	DWG. NO. 5301-7	SHEET 1 OF 1		