

REFERENCE SEASTROM WORKMANSHIP STD. 8.4.1.W2

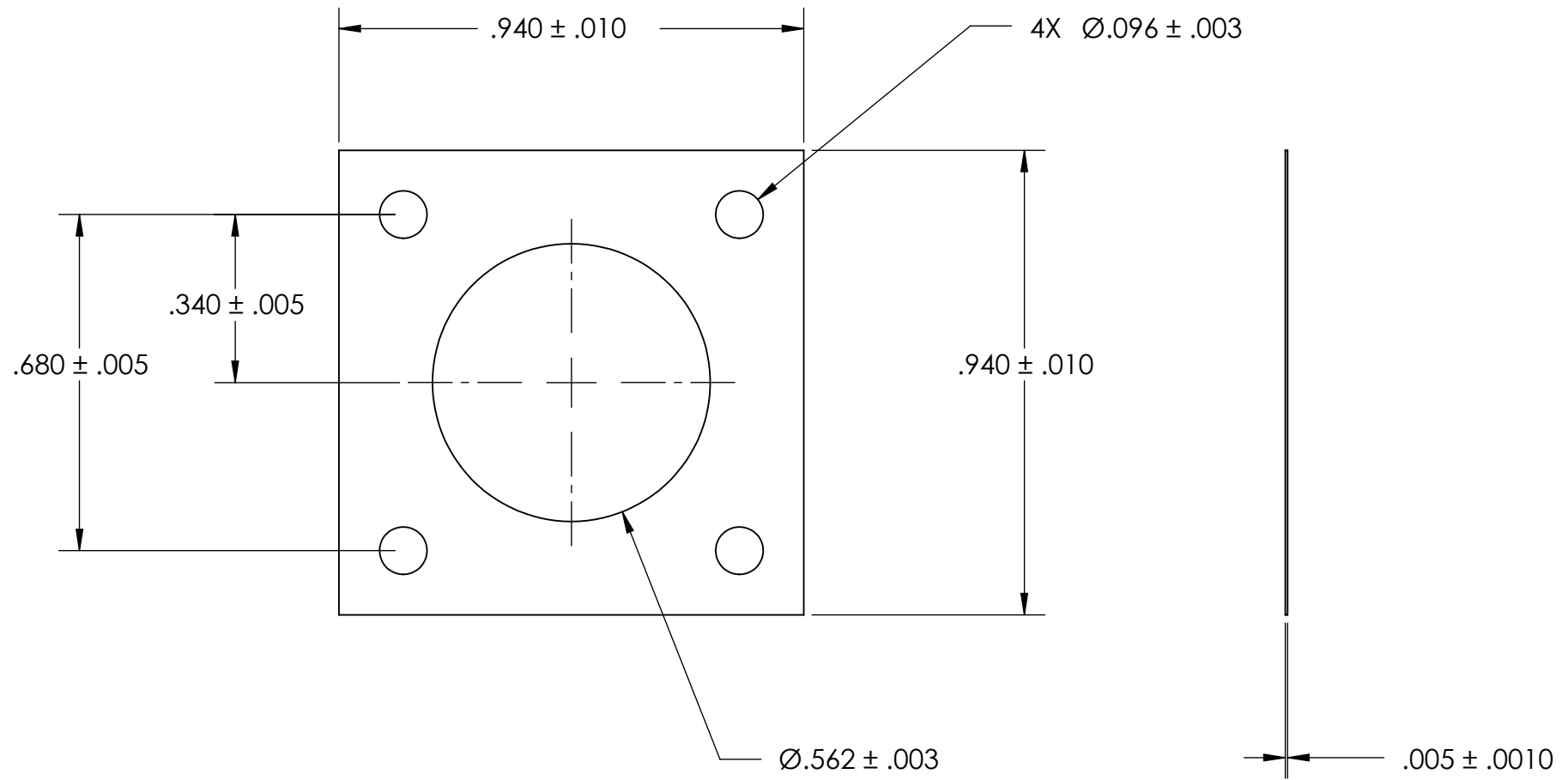

NOTES  
1. CASE STYLE: HiPowrTran

**PROPRIETARY AND CONFIDENTIAL**  
THE INFORMATION CONTAINED IN THIS DRAWING IS THE SOLE PROPERTY OF SEASTROM MANUFACTURING. ANY REPRODUCTION IN PART OR AS A WHOLE WITHOUT THE WRITTEN PERMISSION OF SEASTROM MANUFACTURING IS PROHIBITED.

DIMENSIONS ARE IN INCHES TOLERANCES: FRACTIONAL $\pm 1/32$ ANGULAR: MACH $\pm 1/2$ Deg TWO PLACE DECIMAL $\pm .01$ THREE PLACE DECIMAL $\pm .005$	NAME	DATE	SEASTROM MFG
	DRAWN		
	CHECKED		SOLIDSTATE INSULATE
	ENG APPR.		
	MFG APPR.		
MATERIAL	COMMENTS:		SIZE <b>A</b> DWG. NO. <b>5202-1</b> REV. <b>-</b>
MICA			
FINISH			SHEET 1 OF 1
NONE	DRAWING IS NOT TO SCALE		