

REFERENCE SEASTROM WORKMANSHIP STD. 8.4.1.W2

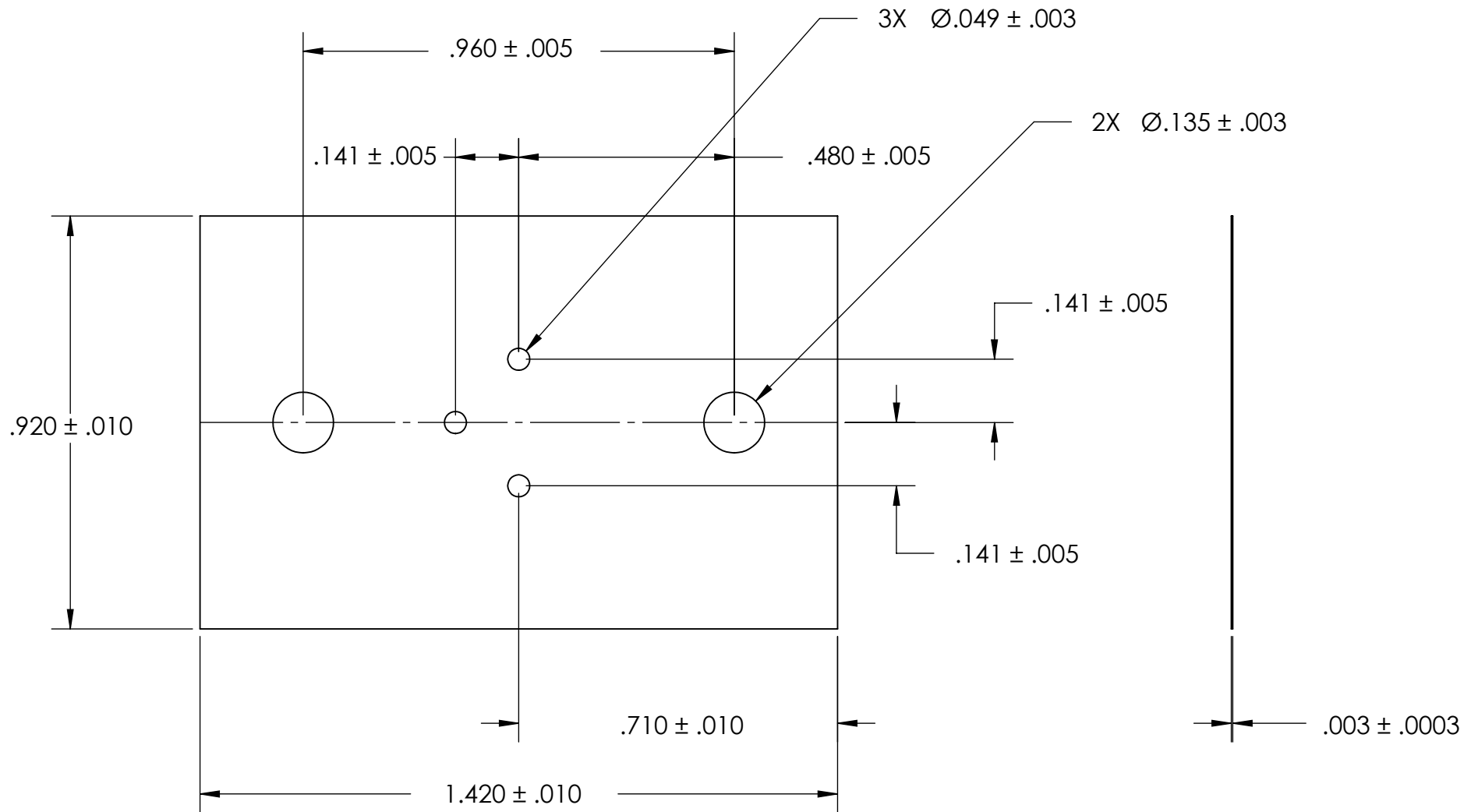

NOTES
1. CASE STYLE: To 8

PROPRIETARY AND CONFIDENTIAL
THE INFORMATION CONTAINED IN THIS DRAWING IS THE SOLE PROPERTY OF SEASTROM MANUFACTURING. ANY REPRODUCTION IN PART OR AS A WHOLE WITHOUT THE WRITTEN PERMISSION OF SEASTROM MANUFACTURING IS PROHIBITED.

DIMENSIONS ARE IN INCHES TOLERANCES: FRACTIONAL ± 1/32 ANGULAR: MACH ± 1/2 Deg TWO PLACE DECIMAL ± .01 THREE PLACE DECIMAL ± .005	NAME	DATE	SEASTROM MFG SOLIDSTATE INSULATE
	DRAWN		
	CHECKED		
	ENG APPR.		
	MFG APPR.		
MATERIAL KAPTON	Q.A.		SIZE DWG. NO. REV. A 5200-2 -
FINISH NONE	COMMENTS:		
DRAWING IS NOT TO SCALE			SHEET 1 OF 1