

REFERENCE SEASTROM WORKMANSHIP STD. 8.4.1.W2

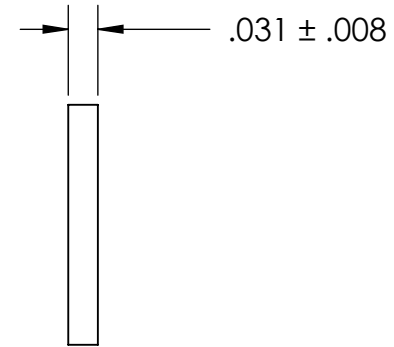
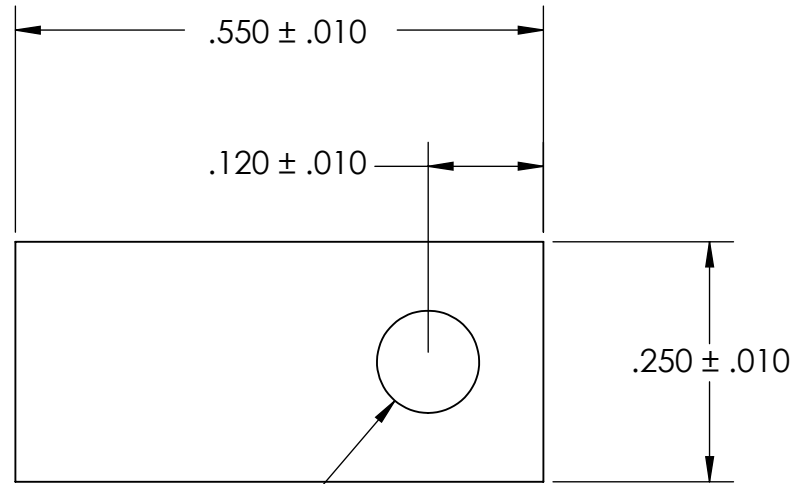

SCREW SIZE # 6

NOTES
1. ODD # STYLE

PROPRIETARY AND CONFIDENTIAL
THE INFORMATION CONTAINED IN THIS DRAWING IS THE SOLE PROPERTY OF SEASTROM MANUFACTURING. ANY REPRODUCTION IN PART OR AS A WHOLE WITHOUT THE WRITTEN PERMISSION OF SEASTROM MANUFACTURING IS PROHIBITED.

DIMENSIONS ARE IN INCHES TOLERANCES: FRACTIONAL $\pm 1/32$ ANGULAR: MACH $\pm 1/2$ Deg TWO PLACE DECIMAL $\pm .01$ THREE PLACE DECIMAL $\pm .005$		NAME	DATE	SEASTROM MFG INSULATING STRIP
	DRAWN			
	CHECKED			
	ENG APPR.			
	MFG APPR.			
MATERIAL	Q.A.			SIZE DWG. NO. REV. A 5102-1 -
FINISH	COMMENTS:			
DRAWING IS NOT TO SCALE				SHEET 1 OF 1