

REFERENCE SEASTROM WORKMANSHIP STD. 8.4.1.W2

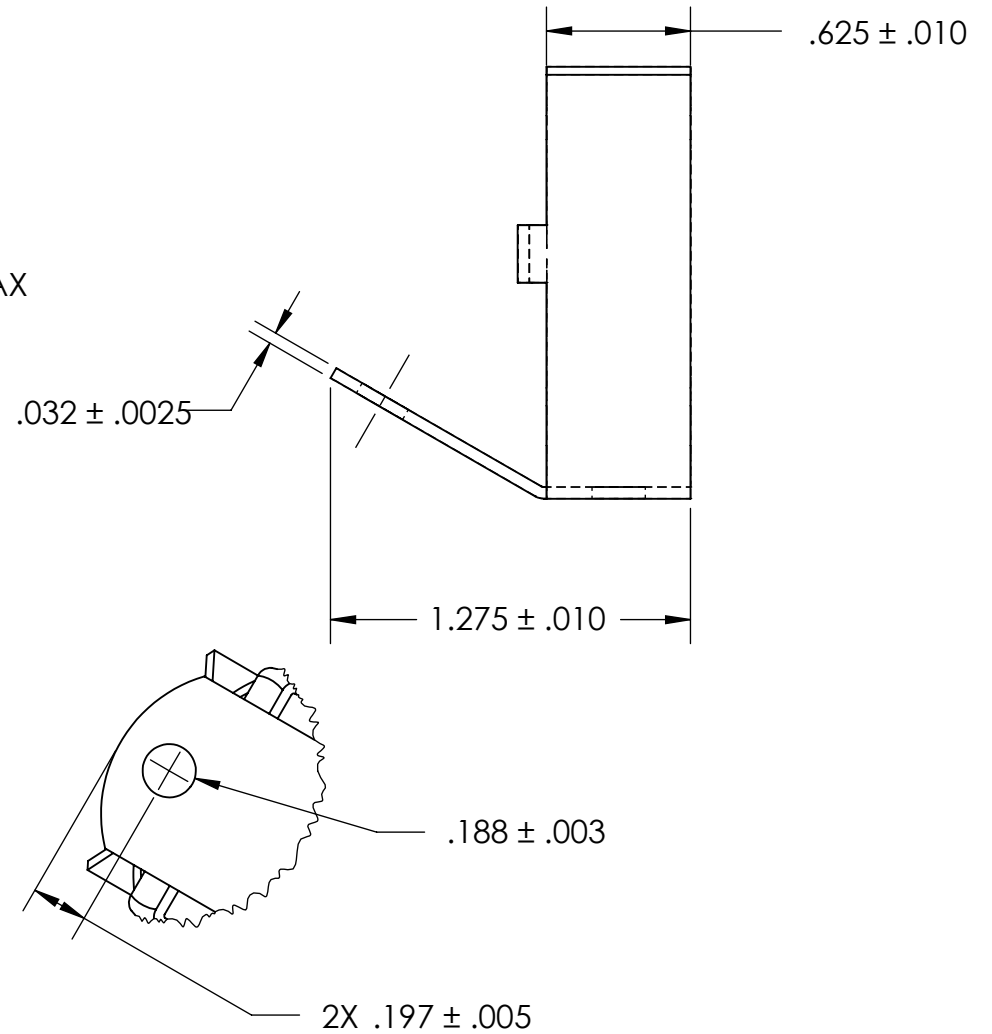
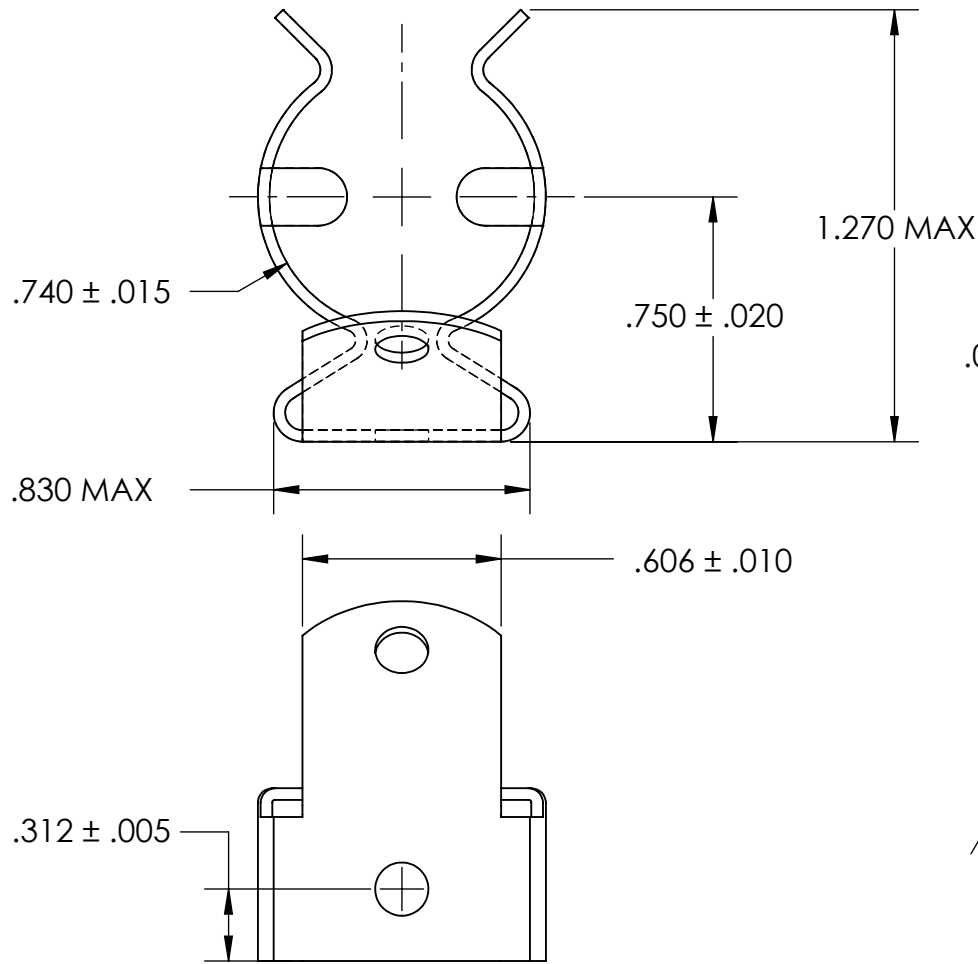

NOTES

1. BERYLLIUM COPPER, ANNEALED
2. HEAT TREAT: 73-79 HR15N
3. NICKEL PLATE PER AMS QQ-N-290 CLASS 1 GRADE G
4. DIMENSIONS ARE TAKEN WITH THE PART CLAMPED TO A FLAT SURFACE AND A DUMMY COMPONENT IN PLACE.
5. DIMENSIONS APPLY PRIOR TO PLATING.

PROPRIETARY AND CONFIDENTIAL

THE INFORMATION CONTAINED IN THIS DRAWING IS THE SOLE PROPERTY OF SEASTROM MANUFACTURING. ANY REPRODUCTION IN PART OR AS A WHOLE WITHOUT THE WRITTEN PERMISSION OF SEASTROM MANUFACTURING IS PROHIBITED.

DIMENSIONS ARE IN INCHES TOLERANCES: FRACTIONAL ± 1/32 ANGULAR: MACH ± 1/2 Deg TWO PLACE DECIMAL ± .01 THREE PLACE DECIMAL ± .005	NAME	DATE	SEASTROM MFG	
	DRAWN			
	CHECKED		SPRING CLIP	
	ENG APPR.			
	MFG APPR.		Q.A.	
MATERIAL SEE NOTE 1	COMMENTS:		SIZE A	DWG. NO. 4572-74-127-1-N
HEAT TREAT SEE NOTE 2			REV. -	
FINISH SEE NOTE 3	DRAWING IS NOT TO SCALE		SHEET 1 OF 1	