

REFERENCE SEASTROM WORKMANSHIP STD. 8.4.1.W2

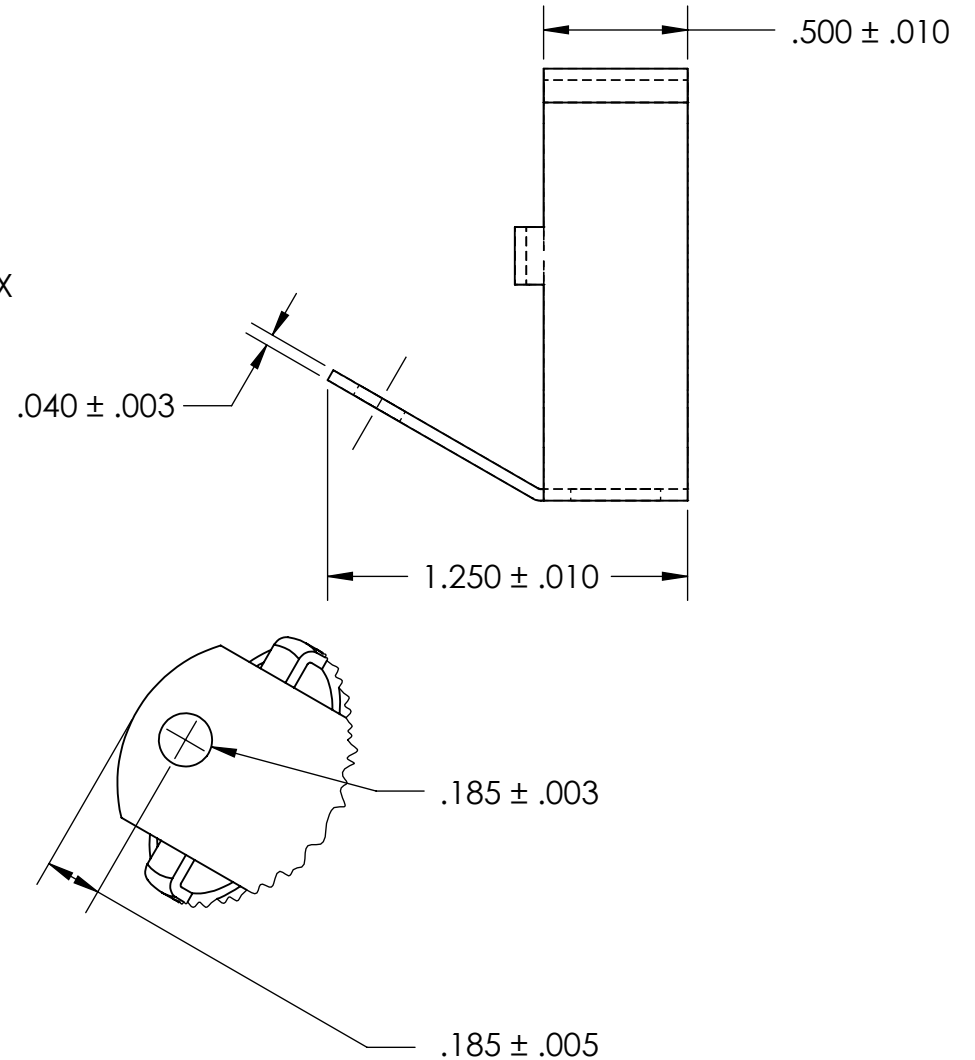
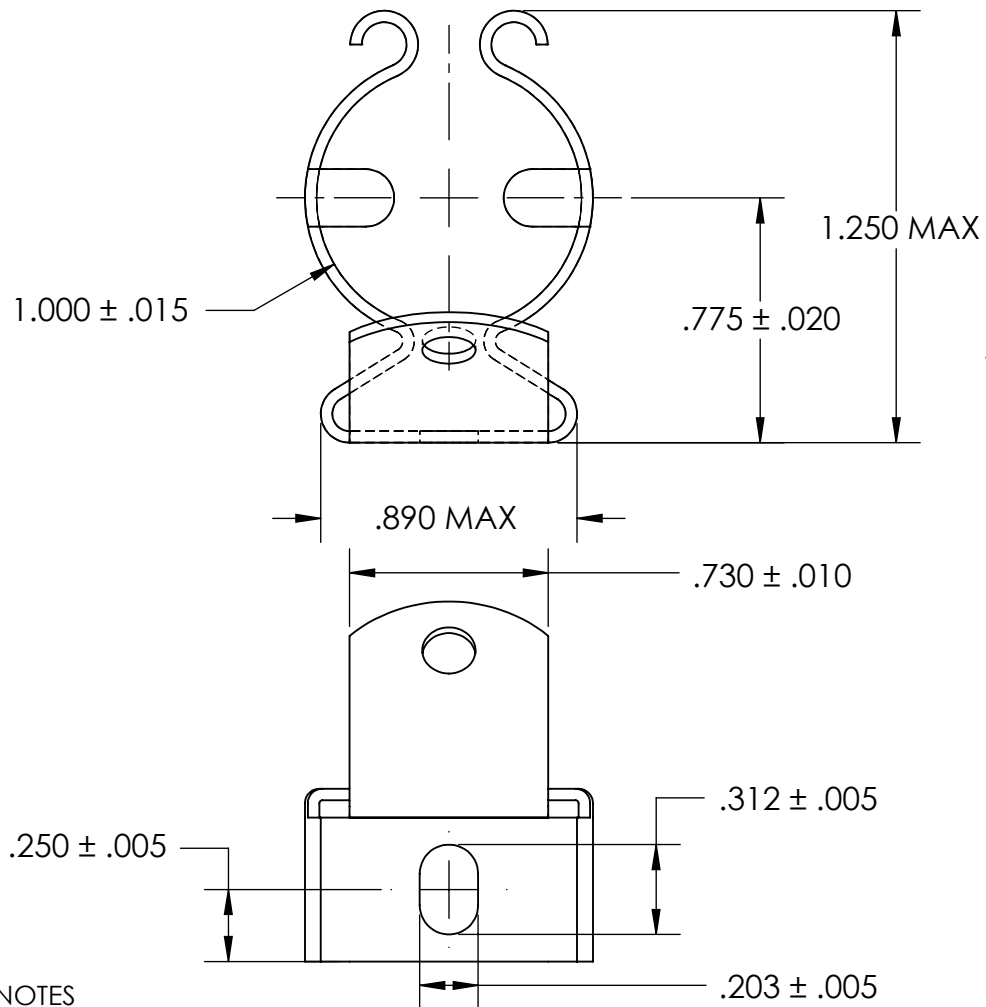

NOTES

1. BERYLLIUM COPPER, ANNEALED

2. HEAT TREAT: 73-79 HR15N

3. NONE

4. DIMENSIONS ARE TAKEN WITH THE PART CLAMPED TO A FLAT SURFACE AND A DUMMY COMPONENT IN PLACE.

PROPRIETARY AND CONFIDENTIAL

THE INFORMATION CONTAINED IN THIS DRAWING IS THE SOLE PROPERTY OF SEASTROM MANUFACTURING. ANY REPRODUCTION IN PART OR AS A WHOLE WITHOUT THE WRITTEN PERMISSION OF SEASTROM MANUFACTURING IS PROHIBITED.

DIMENSIONS ARE IN INCHES TOLERANCES: FRACTIONAL ± 1/32 ANGULAR: MACH ± 1/2 Deg TWO PLACE DECIMAL ± .01 THREE PLACE DECIMAL ± .005	NAME	DATE	SEASTROM MFG	
	DRAWN			
	CHECKED		SPRING CLIP	
	ENG APPR.			
	MFG APPR.		SIZE	DWG. NO.
Q.A.		A	4570-100-124-1	-
COMMENTS:	DRAWING IS NOT TO SCALE		SHEET 1 OF 1	