

REFERENCE SEASTROM WORKMANSHIP STD. 8.4.1.W2

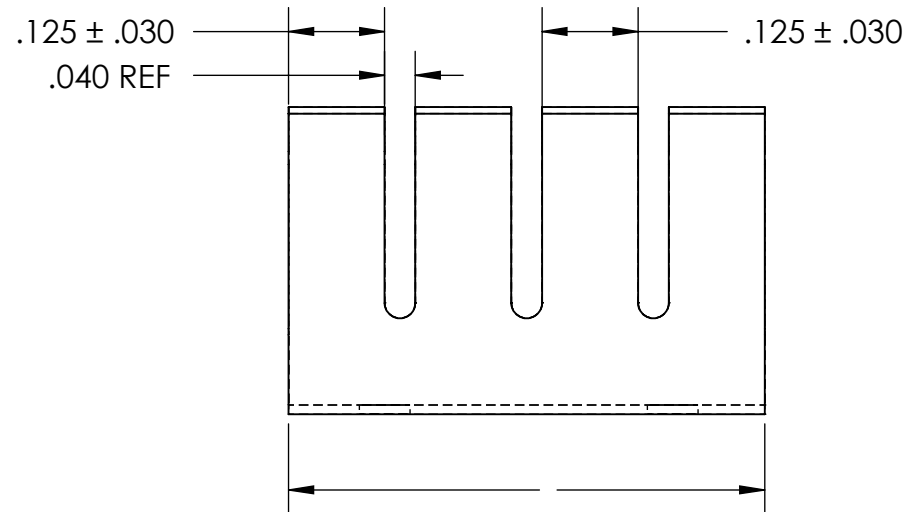
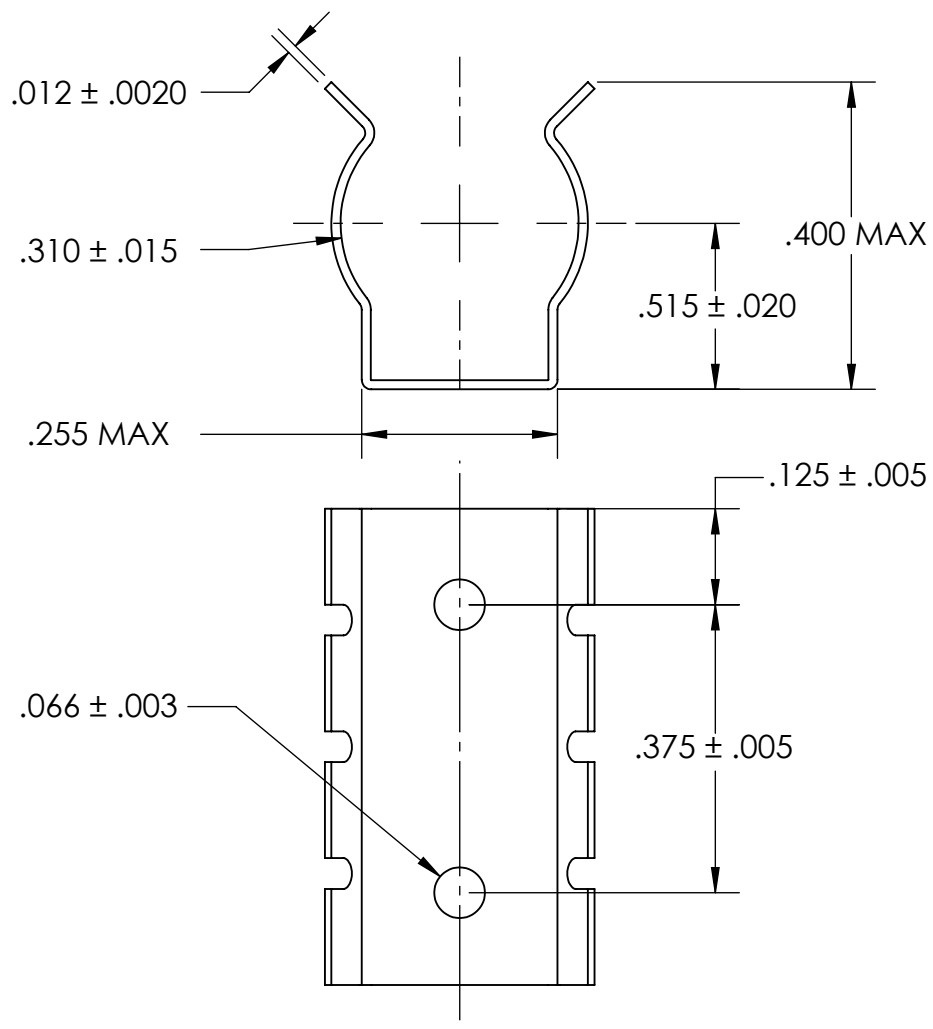

NOTES

1. SPRING STEEL, ANNEALED

2. QUENCH & TEMPER 80-83 HR15N

3. NONE

4. DIMENSIONS ARE TAKEN WITH THE PART CLAMPED TO A FLAT SURFACE AND A DUMMY COMPONENT IN PLACE.

**PROPRIETARY AND CONFIDENTIAL**

THE INFORMATION CONTAINED IN THIS DRAWING IS THE SOLE PROPERTY OF SEASTROM MANUFACTURING. ANY REPRODUCTION IN PART OR AS A WHOLE WITHOUT THE WRITTEN PERMISSION OF SEASTROM MANUFACTURING IS PROHIBITED.

DIMENSIONS ARE IN INCHES TOLERANCES: FRACTIONAL $\pm 1/32$ ANGULAR: MACH $\pm 1/2$ Deg TWO PLACE DECIMAL $\pm .01$ THREE PLACE DECIMAL $\pm .005$	NAME	DATE	<b>SEASTROM MFG</b>  <b>SPRING CLIP</b>
	DRAWN		
	CHECKED		
	ENG APPR.		
	MFG APPR.		
MATERIAL	COMMENTS:		SIZE <b>A</b> DWG. NO. <b>4566-31-62-2</b> REV. <b>-</b>
SEE NOTE 1			
HEAT TREAT			
SEE NOTE 2			
FINISH			
SEE NOTE 3			
DRAWING IS NOT TO SCALE			SHEET 1 OF 1