

REFERENCE SEASTROM WORKMANSHIP STD. 8.4.1.W2

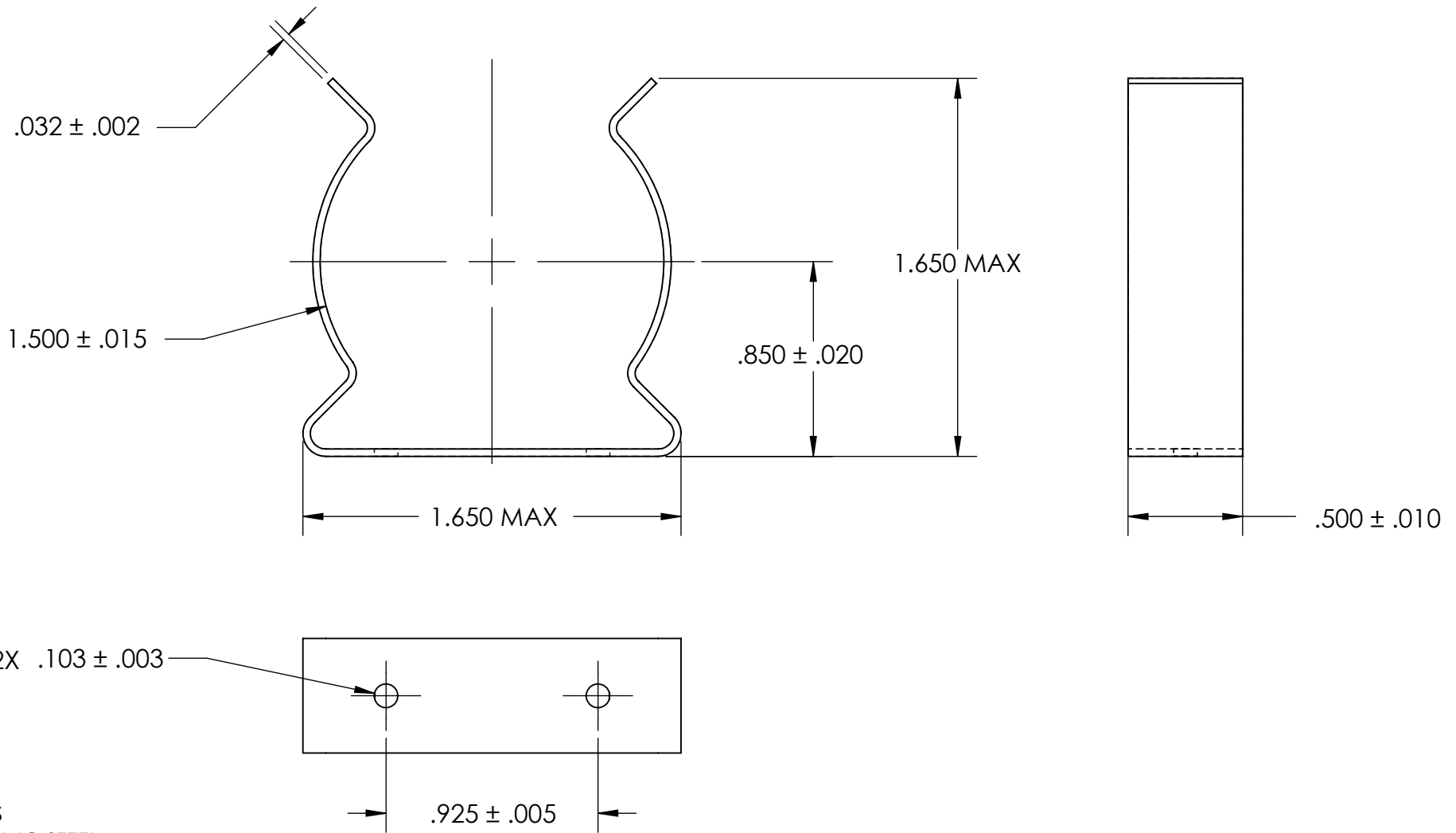

NOTES

1. SPRING STEEL

2. QUENCH & TEMPER: 80-83 HR15N

3. NONE

4. DIMENSIONS ARE TAKEN WITH THE PART CLAMPED TO A FLAT SURFACE AND A DUMMY COMPONENT IN PLACE.

**PROPRIETARY AND CONFIDENTIAL**

THE INFORMATION CONTAINED IN THIS DRAWING IS THE SOLE PROPERTY OF SEASTROM MANUFACTURING. ANY REPRODUCTION IN PART OR AS A WHOLE WITHOUT THE WRITTEN PERMISSION OF SEASTROM MANUFACTURING IS PROHIBITED.

DIMENSIONS ARE IN INCHES TOLERANCES: FRACTIONAL $\pm 1/32$ ANGULAR: MACH $\pm 1/2$ Deg TWO PLACE DECIMAL $\pm .01$ THREE PLACE DECIMAL $\pm .005$		NAME	DATE	<b>SEASTROM MFG</b>
MATERIAL SEE NOTE 1	DRAWN			
HEAT TREAT SEE NOTE 2	CHECKED			<b>SPRING CLIP</b>
FINISH SEE NOTE 3	ENG APPR.			
	MFG APPR.			
	Q.A.			
	COMMENTS:			
	SIZE	DWG. NO.	REV.	
	<b>A</b>	<b>4561-150-50-2</b>	-	
DRAWING IS NOT TO SCALE			SHEET 1 OF 1	