

REFERENCE SEASTROM WORKMANSHIP STD. 8.4.1.W2

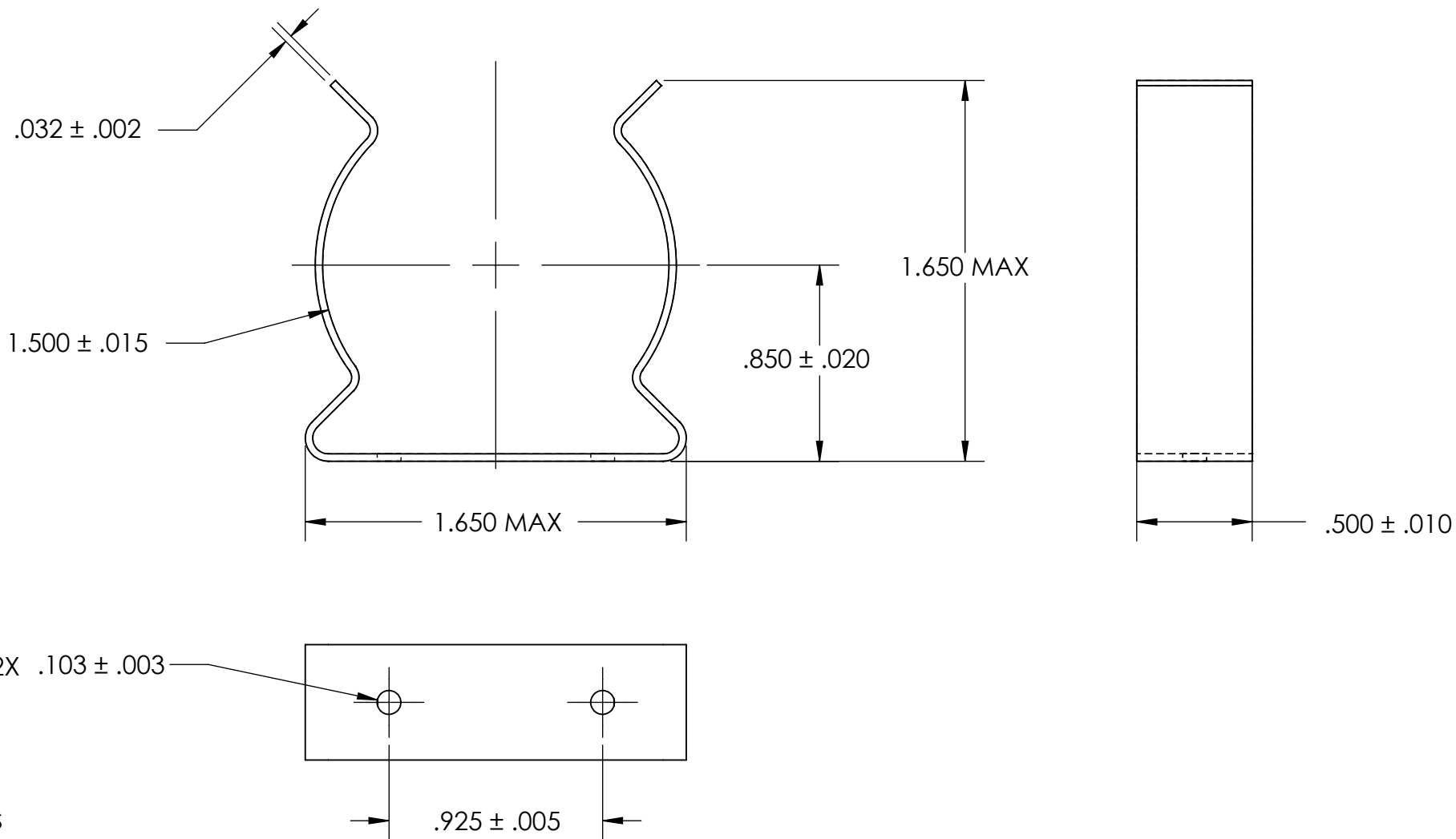

NOTES

1. SPRING STEEL
2. QUENCH & TEMPER: 80-83 HR15N
3. CADMIUM PLATE PER AMS QQ-P-416 TYPE II CLASS 2 w/BAKE
4. DIMENSIONS ARE TAKEN WITH THE PART CLAMPED TO A FLAT SURFACE AND A DUMMY COMPONENT IN PLACE.
5. DIMENSIONS APPLY PRIOR TO PLATING.

PROPRIETARY AND CONFIDENTIAL

THE INFORMATION CONTAINED IN THIS DRAWING IS THE SOLE PROPERTY OF SEASTROM MANUFACTURING. ANY REPRODUCTION IN PART OR AS A WHOLE WITHOUT THE WRITTEN PERMISSION OF SEASTROM MANUFACTURING IS PROHIBITED.

DIMENSIONS ARE IN INCHES TOLERANCES: FRACTIONAL $\pm 1/32$ ANGULAR: MACH $\pm 1/2$ Deg TWO PLACE DECIMAL $\pm .01$ THREE PLACE DECIMAL $\pm .005$	NAME	DATE	SEASTROM MFG SPRING CLIP
	DRAWN		
	CHECKED		
	ENG APPR.		
	MFG APPR.		
MATERIAL	COMMENTS:		SIZE
SEE NOTE 1			A
HEAT TREAT			DWG. NO.
SEE NOTE 2			4561-150-50-2-C2
FINISH			REV.
SEE NOTE 3			-
DRAWING IS NOT TO SCALE			SHEET 1 OF 1