

REFERENCE SEASTROM WORKMANSHIP STD. 8.4.1.W2

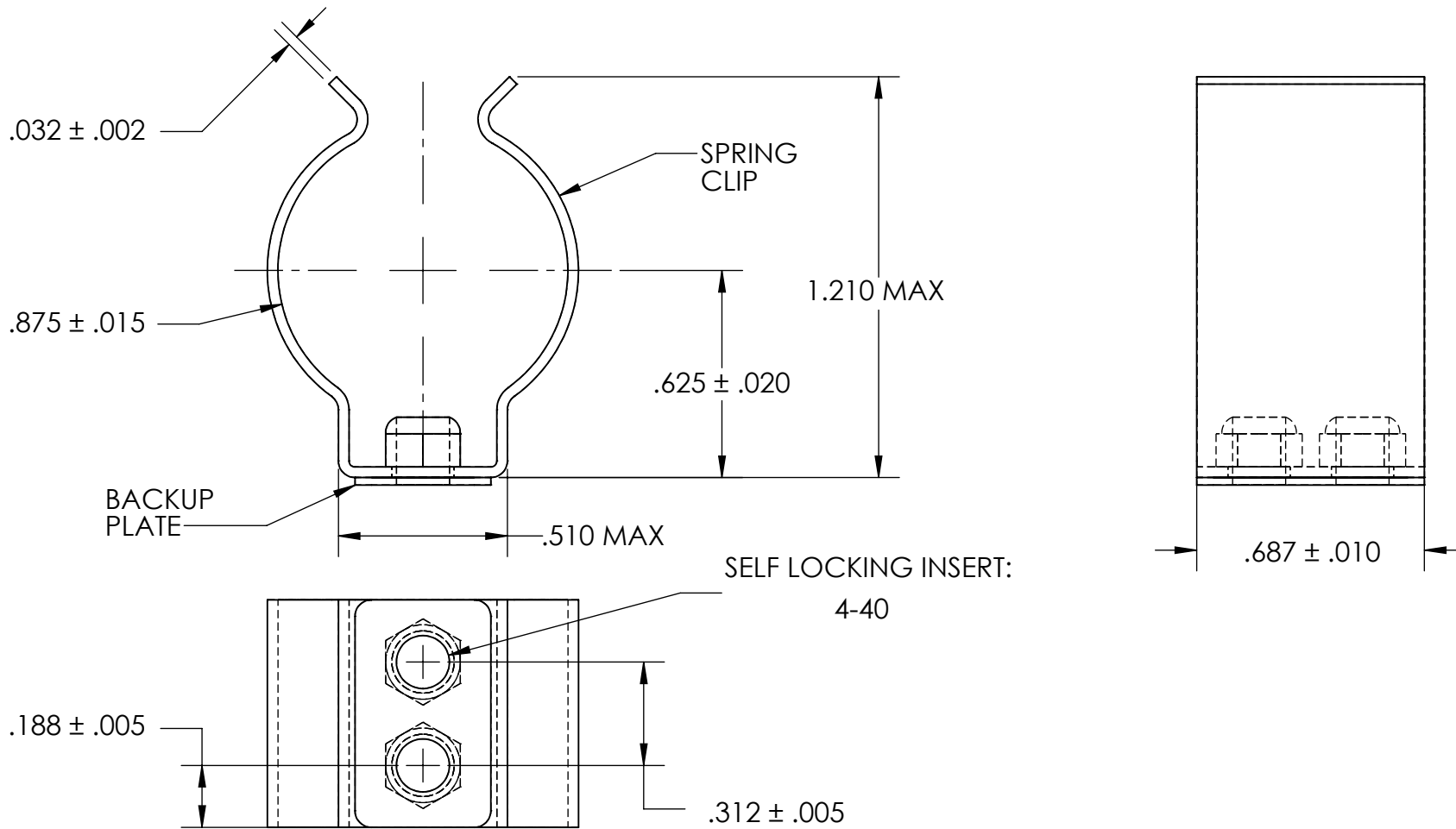

NOTES

1. SPRING STEEL, ANNEALED
2. QUENCH & TEMPER 80-83 HR15N (SPRING CLIP ONLY)
3. NICKEL PLATE PER AMS QQ-N-290 CLASS 1 GRADE G w/BAKE (SPRING CLIP AND BACKUP PLATE)
4. DIMENSIONS ARE TAKEN WITH THE PART CLAMPED TO A FLAT SURFACE AND A DUMMY COMPONENT IN PLACE.
5. DIMENSIONS APPLY PRIOR TO PLATING.

**PROPRIETARY AND CONFIDENTIAL**  
 THE INFORMATION CONTAINED IN THIS DRAWING IS THE SOLE PROPERTY OF SEASTROM MANUFACTURING. ANY REPRODUCTION IN PART OR AS A WHOLE WITHOUT THE WRITTEN PERMISSION OF SEASTROM MANUFACTURING IS PROHIBITED.

|  |  |           |      |  |
|--|--|-----------|------|--|
| DIMENSIONS ARE IN INCHES<br>TOLERANCES:<br>FRACTIONAL ± 1/32<br>ANGULAR: MACH ± 1/2 Deg<br>TWO PLACE DECIMAL ± .01<br>THREE PLACE DECIMAL ± .005 |  | NAME      | DATE | <b>SEASTROM MFG</b>  |
| MATERIAL<br>SEE NOTE 1   |  | DRAWN     |      |  |
| HEAT TREAT<br>SEE NOTE 2   |  | CHECKED   |      | SIZE <b>A</b> DWG. NO. <b>4543-87-68-2-N</b> REV. <b>-</b> |
| FINISH<br>SEE NOTE 3   |  | ENG APPR. |      |  |
|  |  | MFG APPR. |      | SHEET 1 OF 1   |
|  |  | Q.A.      |      |  |
|  |  | COMMENTS: |      |  |