

REFERENCE SEASTROM WORKMANSHIP STD. 8.4.1.W2

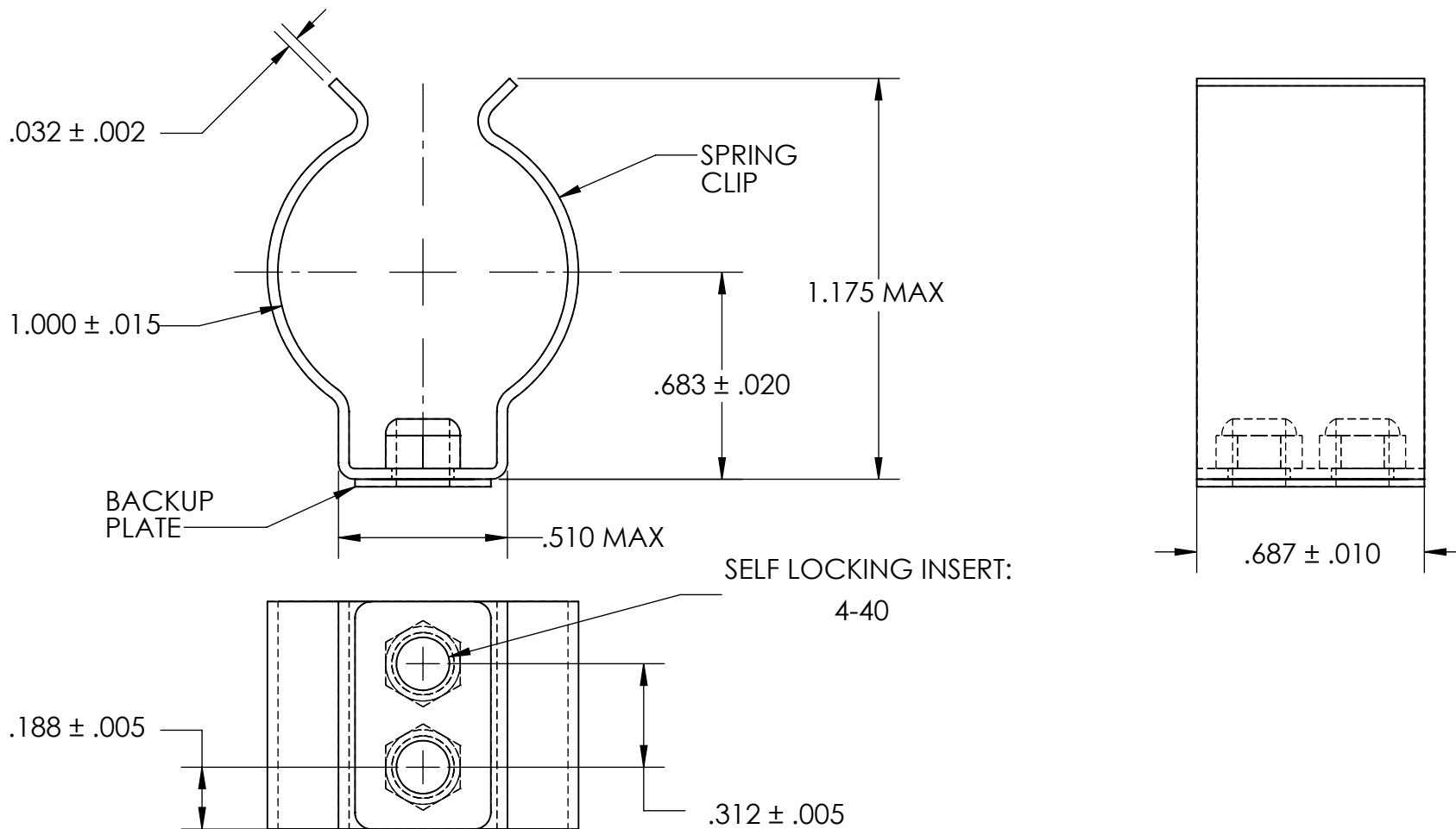

NOTES

1. SPRING STEEL, ANNEALED
2. QUENCH & TEMPER 80-83 HR15N (SPRING CLIP ONLY)
3. CADMIUM PLATE PER AMS QQ-P-416 TYPE II CLASS 2 w/BAKE (SPRING CLIP AND BACKUP PLATE)
4. DIMENSIONS ARE TAKEN WITH THE PART CLAMPED TO A FLAT SURFACE AND A DUMMY COMPONENT IN PLACE.
5. DIMENSIONS APPLY PRIOR TO PLATING.

**PROPRIETARY AND CONFIDENTIAL**  
 THE INFORMATION CONTAINED IN THIS DRAWING IS THE SOLE PROPERTY OF SEASTROM MANUFACTURING. ANY REPRODUCTION IN PART OR AS A WHOLE WITHOUT THE WRITTEN PERMISSION OF SEASTROM MANUFACTURING IS PROHIBITED.

DIMENSIONS ARE IN INCHES TOLERANCES: FRACTIONAL ± 1/32 ANGULAR: MACH ± 1/2 Deg TWO PLACE DECIMAL ± .01 THREE PLACE DECIMAL ± .005		NAME	DATE	SEASTROM MFG
MATERIAL SEE NOTE 1		DRAWN		
HEAT TREAT SEE NOTE 2		CHECKED		SPRING CLIP
FINISH SEE NOTE 3		ENG APPR.		
		MFG APPR.		
		Q.A.		
		COMMENTS:		
		SIZE	DWG. NO.	REV.
		A	4543-100-68-2-C2	-
DRAWING IS NOT TO SCALE			SHEET 1 OF 1	