

REFERENCE SEASTROM WORKMANSHIP STD. 8.4.1.W2

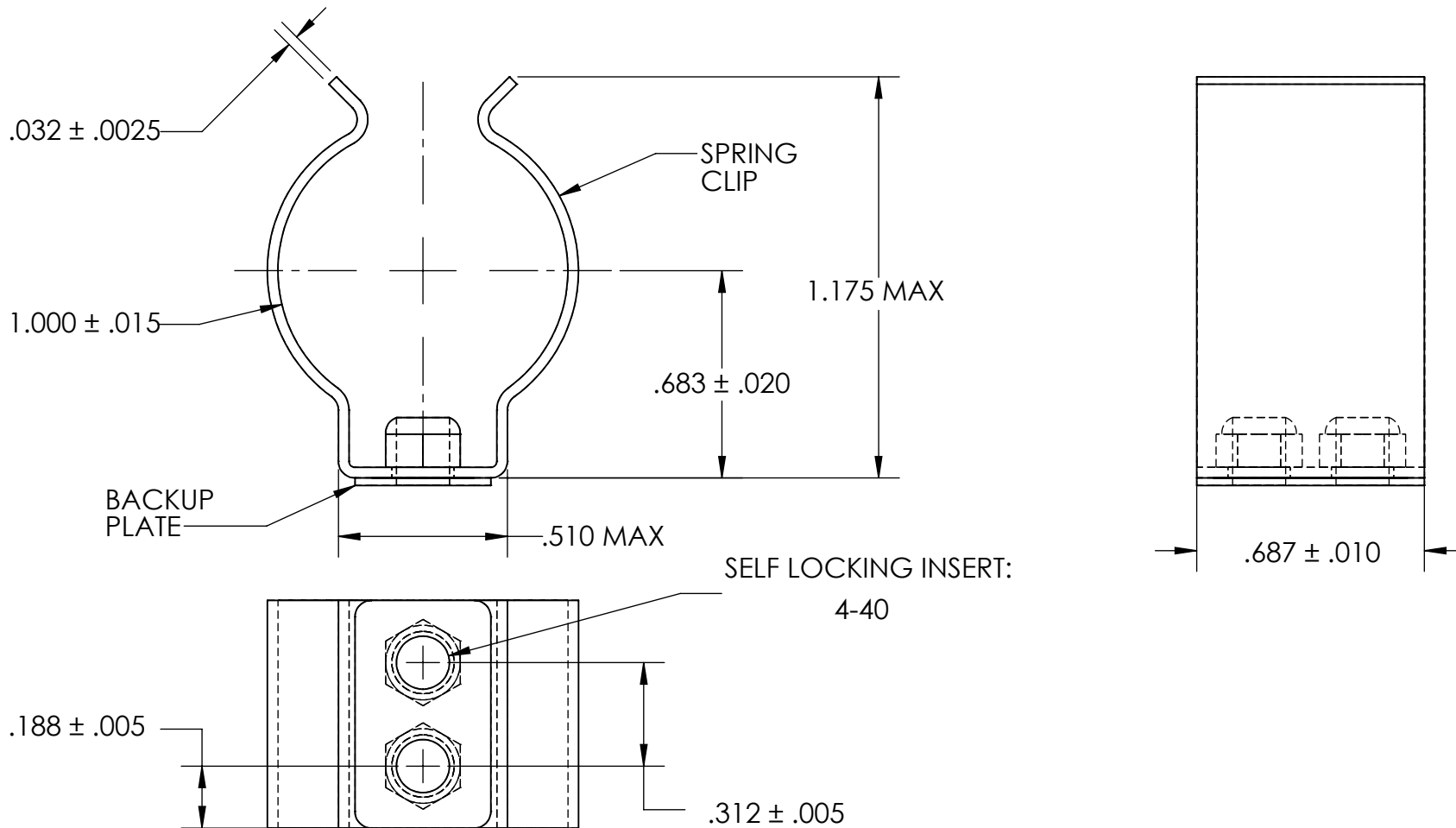

NOTES

1. BERYLLIUM COPPER, ANNEALED

2. HEAT TREAT: 73-79 HR15N

(SPRING CLIP ONLY)

3. NONE

(SPRING CLIP AND BACKUP PLATE)

4. DIMENSIONS ARE TAKEN WITH THE PART CLAMPED TO A FLAT SURFACE AND A DUMMY COMPONENT IN PLACE.

**PROPRIETARY AND CONFIDENTIAL**

THE INFORMATION CONTAINED IN THIS DRAWING IS THE SOLE PROPERTY OF SEASTROM MANUFACTURING. ANY REPRODUCTION IN PART OR AS A WHOLE WITHOUT THE WRITTEN PERMISSION OF SEASTROM MANUFACTURING IS PROHIBITED.

|  |           |               |                               |                     |
|--|-----------|---------------|-------------------------------|---------------------|
| DIMENSIONS ARE IN INCHES<br>TOLERANCES:<br>FRACTIONAL ± 1/32<br>ANGULAR: MACH ± 1/2 Deg<br>TWO PLACE DECIMAL ± .01<br>THREE PLACE DECIMAL ± .005 |           | NAME          | DATE                          | <b>SEASTROM MFG</b> |
| MATERIAL<br>SEE NOTE 1   | DRAWN     |               |                               |                     |
| HEAT TREAT<br>SEE NOTE 2   | CHECKED   |               |                               | <b>SPRING CLIP</b>  |
| FINISH<br>SEE NOTE 3   | ENG APPR. |               |                               |                     |
|  | MFG APPR. |               |                               |                     |
|  | Q.A.      |               |                               |                     |
| COMMENTS:  |           |               |                               |                     |
|  |           | SIZE <b>A</b> | DWG. NO. <b>4543-100-68-1</b> | REV. <b>-</b>       |
| DRAWING IS NOT TO SCALE  |           |               |                               | SHEET 1 OF 1        |