

REFERENCE SEASTROM WORKMANSHIP STD. 8.4.1.W2

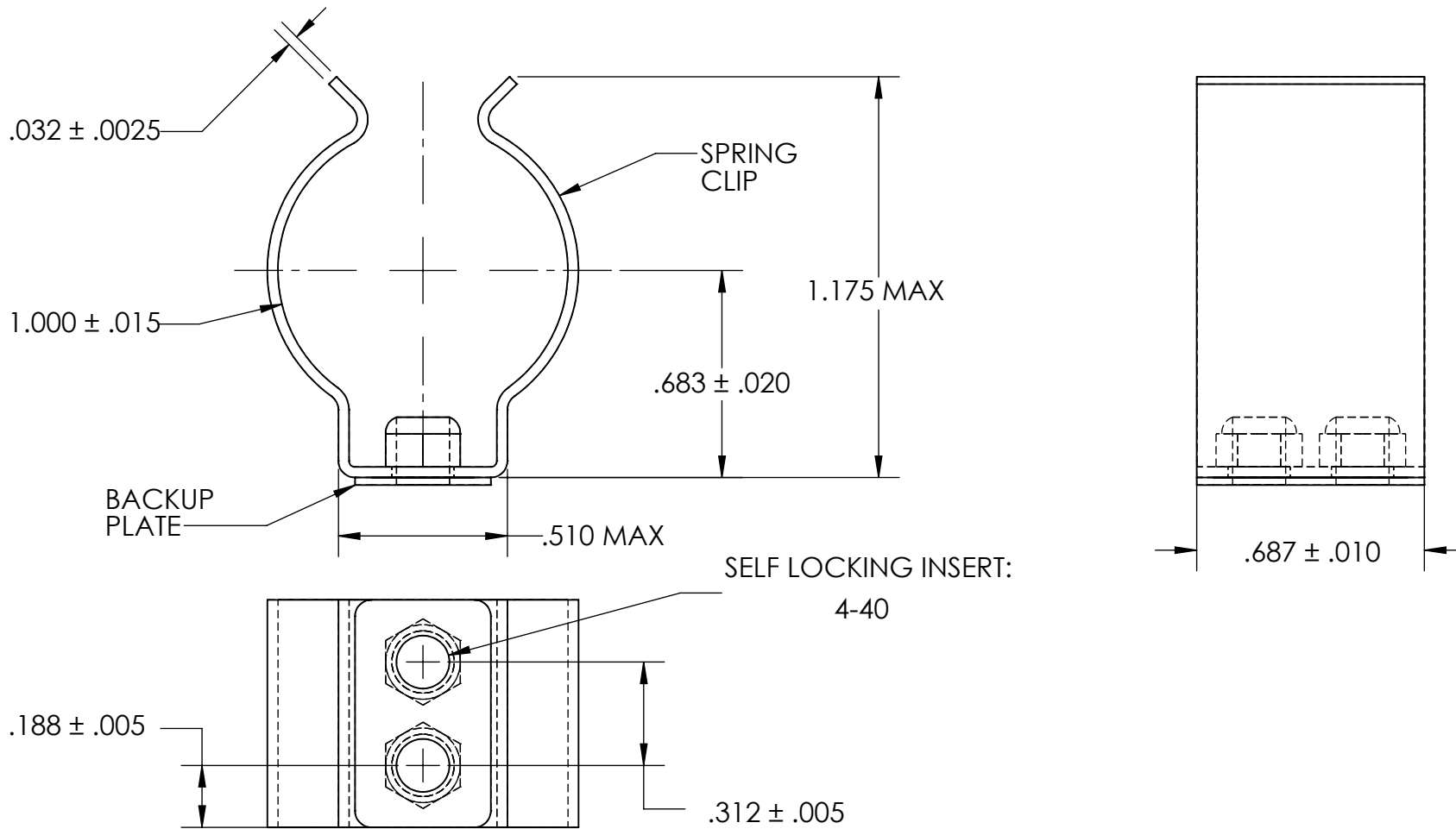

NOTES

1. BERYLLIUM COPPER, ANNEALED
2. HEAT TREAT: 73-79 HR15N (SPRING CLIP ONLY)
3. SILVER PLATE PER ASTM B700 TYPE 1 GRADE A CLASS S,  $2.5\mu\text{m}$  TH w/NICKEL UNDERPLATE (SPRING CLIP AND BACKUP PLATE)
4. DIMENSIONS ARE TAKEN WITH THE PART CLAMPED TO A FLAT SURFACE AND A DUMMY COMPONENT IN PLACE.
5. DIMENSIONS APPLY PRIOR TO PLATING.

**PROPRIETARY AND CONFIDENTIAL**  
 THE INFORMATION CONTAINED IN THIS DRAWING IS THE SOLE PROPERTY OF SEASTROM MANUFACTURING. ANY REPRODUCTION IN PART OR AS A WHOLE WITHOUT THE WRITTEN PERMISSION OF SEASTROM MANUFACTURING IS PROHIBITED.

|  |  |           |      |   |
|--|--|-----------|------|---|
| DIMENSIONS ARE IN INCHES<br>TOLERANCES:<br>FRACTIONAL $\pm 1/32$<br>ANGULAR: MACH $\pm 1/2$ Deg<br>TWO PLACE DECIMAL $\pm .01$<br>THREE PLACE DECIMAL $\pm .005$ |  | NAME      | DATE | SEASTROM MFG                                  |
| MATERIAL<br>SEE NOTE 1   |  |           |      |   |
| HEAT TREAT<br>SEE NOTE 2   |  | Q.A.      |      | SIZE <b>A</b> DWG. NO. 4543-100-68-1-S REV. - |
| FINISH<br>SEE NOTE 3   |  | COMMENTS: |      |   |
| SHEET 1 OF 1   |  |           |      |   |