

REFERENCE SEASTROM WORKMANSHIP STD. 8.4.1.W2

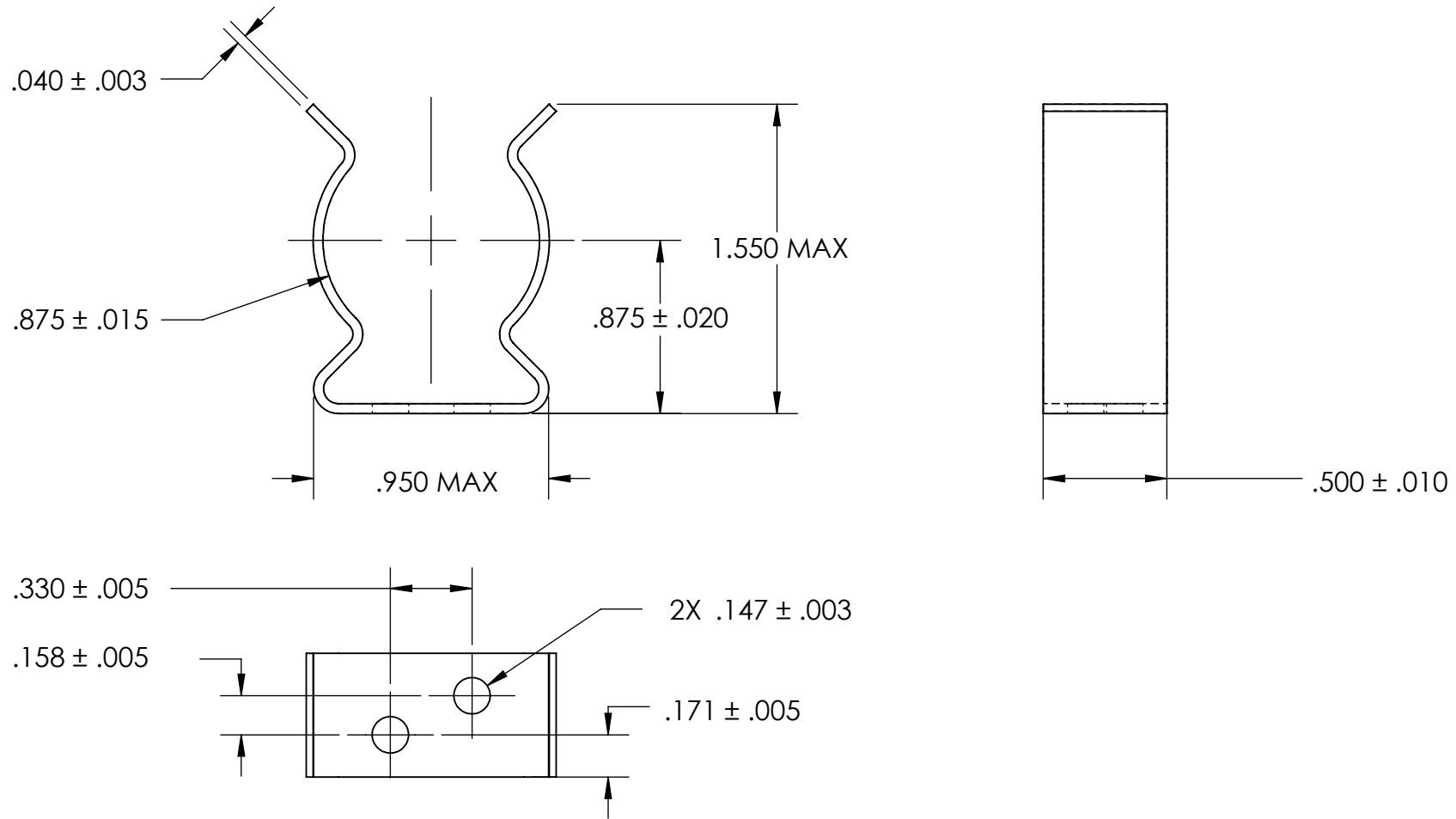

NOTES

1. SPRING STEEL
2. QUENCH & TEMPER: 80-83 HR15N
3. NONE
4. DIMENSIONS ARE TAKEN WITH THE PART CLAMPED TO A FLAT SURFACE AND A DUMMY COMPONENT IN PLACE.

**PROPRIETARY AND CONFIDENTIAL**  
 THE INFORMATION CONTAINED IN THIS DRAWING IS THE SOLE PROPERTY OF SEASTROM MANUFACTURING. ANY REPRODUCTION IN PART OR AS A WHOLE WITHOUT THE WRITTEN PERMISSION OF SEASTROM MANUFACTURING IS PROHIBITED.

DIMENSIONS ARE IN INCHES TOLERANCES: FRACTIONAL ± 1/32 ANGULAR: MACH ± 1/2 Deg TWO PLACE DECIMAL ± .01 THREE PLACE DECIMAL ± .005		NAME	DATE	SEASTROM MFG
MATERIAL SEE NOTE 1	HEAT TREAT SEE NOTE 2	DRAWN	CHECKED	
FINISH SEE NOTE 3	COMMENTS:	ENG APPR.	MFG APPR.	SPRING CLIP
		Q.A.		
		DRAWING IS NOT TO SCALE		SIZE DWG. NO. REV. <b>A</b> 4515-87-50-2 -
				SHEET 1 OF 1