

REFERENCE SEASTROM WORKMANSHIP STD. 8.4.1.W2

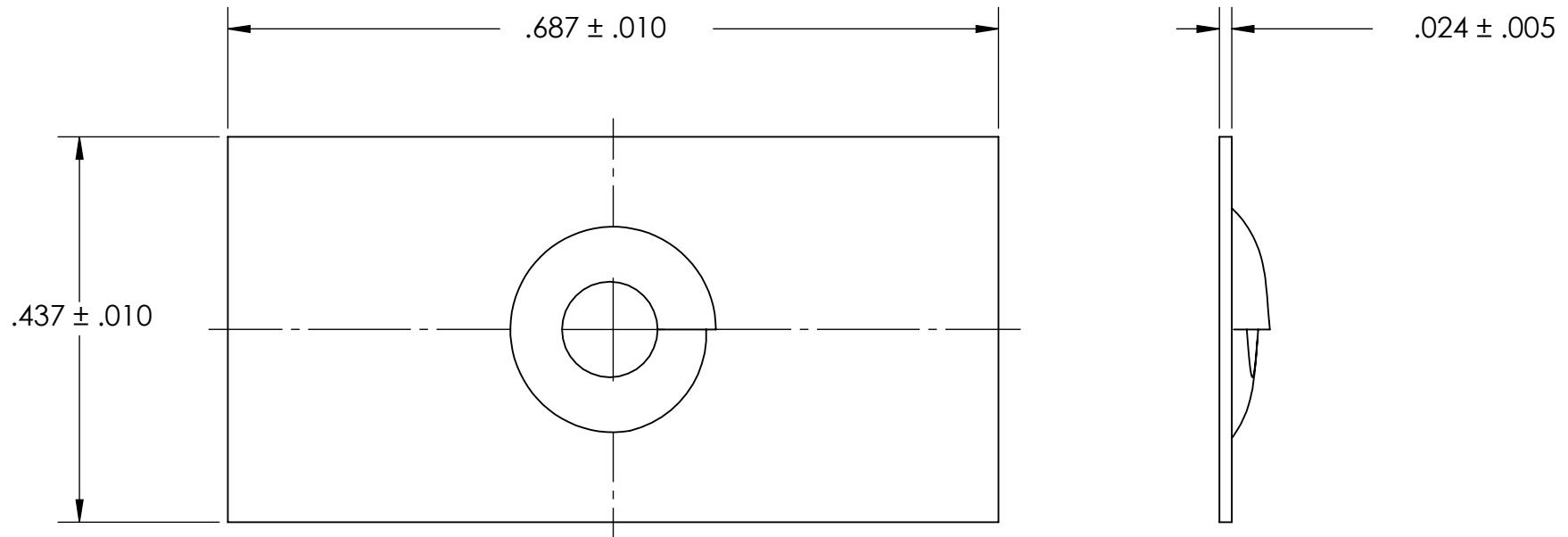

NOTES

1. NONE
2. SCREW SIZE: 6-20
3. SCREW TYPE: B & AB

**PROPRIETARY AND CONFIDENTIAL**  
 THE INFORMATION CONTAINED IN THIS DRAWING IS THE SOLE PROPERTY OF SEASTROM MANUFACTURING. ANY REPRODUCTION IN PART OR AS A WHOLE WITHOUT THE WRITTEN PERMISSION OF SEASTROM MANUFACTURING IS PROHIBITED.

DIMENSIONS ARE IN INCHES TOLERANCES: FRACTIONAL $\pm 1/32$ ANGULAR: MACH $\pm 1/2$ Deg TWO PLACE DECIMAL $\pm .01$ THREE PLACE DECIMAL $\pm .005$		NAME	DATE	SEASTROM MFG
MATERIAL COLD ROLLED STEEL	DRAWN			
FINISH SEE NOTE 1	CHECKED			TAPPED NUT STRIP
DRAWING IS NOT TO SCALE	ENG APPR.			
		MFG APPR.		
	Q.A.			SIZE DWG. NO. REV.
	COMMENTS:			<b>A</b> 2720-11 -
				SHEET 1 OF 1