

Ø.250 ± .010

Ø.512 ± .005

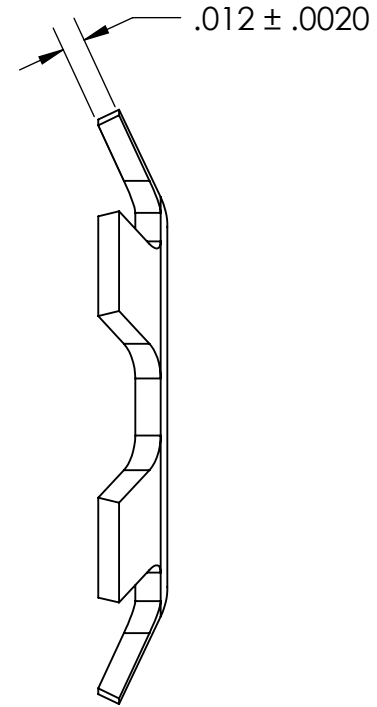
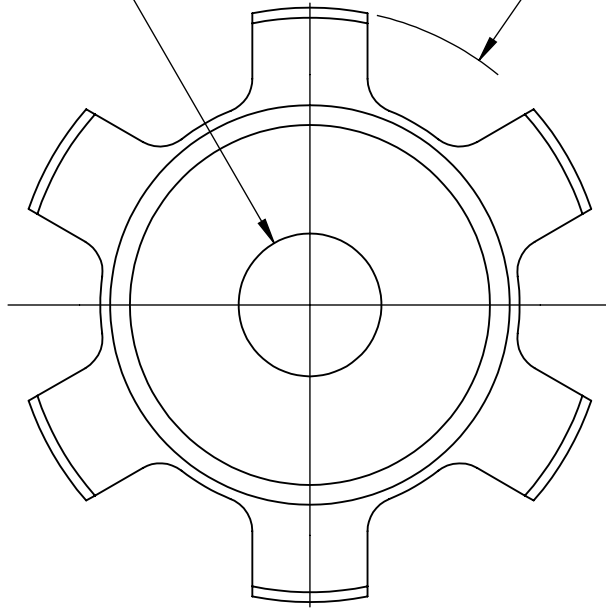

NOTES

1. ZINC PLATE PER ASTM B633, SC1, TYPE III or V, Clear w/Bake
2. HEAT TREAT: 82.5 - 84.5 HR15N
3. No. TABS: 8, EQUALLY SPACED.
4. DESIGN HOLE SIZE: Ø.500 ± .002
5. DIMENSIONS APPLY PRIOR TO PLATING.

PROPRIETARY AND CONFIDENTIAL

THE INFORMATION CONTAINED IN THIS DRAWING IS THE SOLE PROPERTY OF SEASTROM MANUFACTURING. ANY REPRODUCTION IN PART OR AS A WHOLE WITHOUT THE WRITTEN PERMISSION OF SEASTROM MANUFACTURING IS PROHIBITED.

DIMENSIONS ARE IN INCHES TOLERANCES: FRACTIONAL ± 1/32 ANGULAR: MACH ± 1/2 Deg TWO PLACE DECIMAL ± .01 THREE PLACE DECIMAL ± .005		NAME	DATE	SEASTROM MFG
MATERIAL HIGH CARBON SPRING STEEL	FINISH SEE NOTE 1	DRAWN	CHECKED	
DRAWING IS NOT TO SCALE		ENG APPR.	MFG APPR.	SIZE A DWG. NO. 2715-3 REV. -
		Q.A.	COMMENTS:	