

REFEERENCE SEASTROM WORKMANSHIP STD. 8.4.1.W2

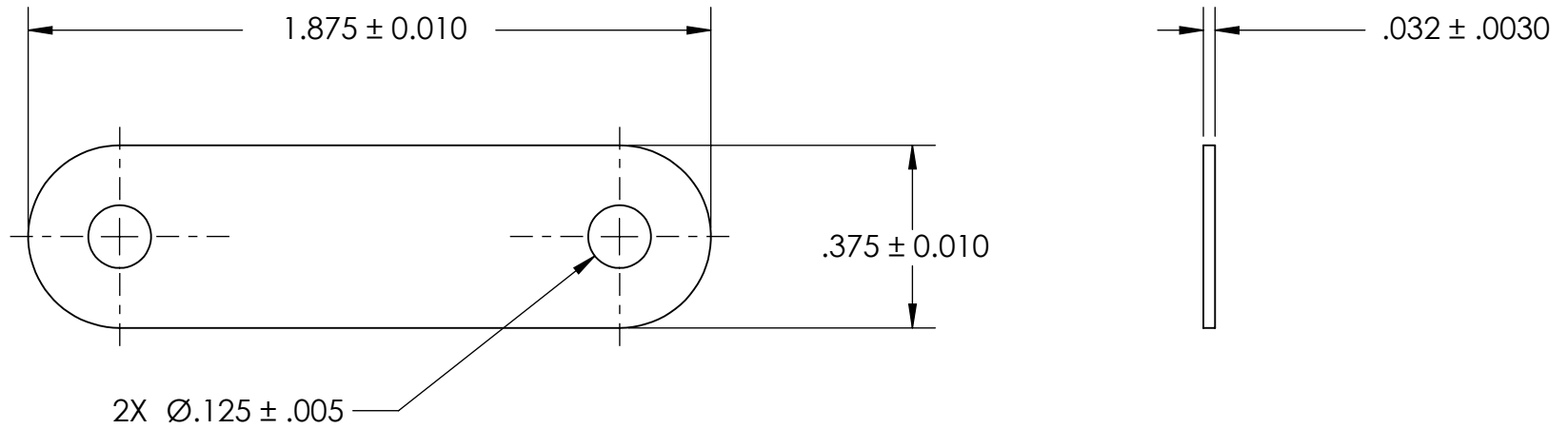

NOTES

1. NONE

2. SCREW SIZE: 4

PROPRIETARY AND CONFIDENTIAL
 THE INFORMATION CONTAINED IN THIS DRAWING IS THE SOLE PROPERTY OF SEASTROM MANUFACTURING. ANY REPRODUCTION IN PART OR AS A WHOLE WITHOUT THE WRITTEN PERMISSION OF SEASTROM MANUFACTURING IS PROHIBITED.

DIMENSIONS ARE IN INCHES TOLERANCES: FRACTIONAL ± 1/32 ANGULAR: MACH ± 1/2 Deg TWO PLACE DECIMAL ± .01 THREE PLACE DECIMAL ± .005	NAME	DATE	SEASTROM MFG TAGS AND MARKER BANDS
	DRAWN		
	CHECKED		
	ENG APPR.		
	MFG APPR.		
MATERIAL	COMMENTS:		SIZE DWG. NO. REV. A 1027-1 -
FINISH			
SEE NOTE 1			
DRAWING IS NOT TO SCALE			SHEET 1 OF 1