

REFERENCE SEASTROM WORKMANSHIP STD. 8.4.1.W2

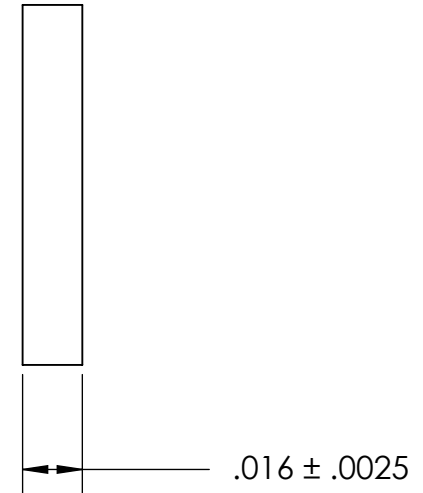
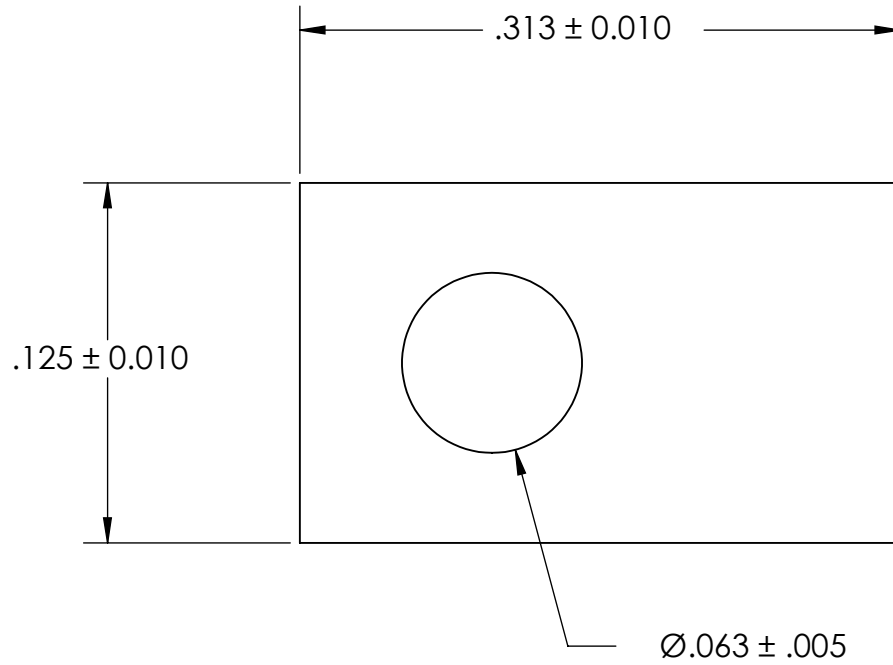

NOTES
1. NONE

2. SCREW SIZE: 0

PROPRIETARY AND CONFIDENTIAL
THE INFORMATION CONTAINED IN THIS DRAWING IS THE SOLE PROPERTY OF SEASTROM MANUFACTURING. ANY REPRODUCTION IN PART OR AS A WHOLE WITHOUT THE WRITTEN PERMISSION OF SEASTROM MANUFACTURING IS PROHIBITED.

DIMENSIONS ARE IN INCHES TOLERANCES: FRACTIONAL ± 1/32 ANGULAR: MACH ± 1/2 Deg TWO PLACE DECIMAL ± .01 THREE PLACE DECIMAL ± .005		NAME	DATE	SEASTROM MFG TAGS AND MARKER BANDS
	DRAWN			
	CHECKED			
	ENG APPR.			
	MFG APPR.			
MATERIAL BRASS	Q.A.			REV. -
FINISH SEE NOTE 1	COMMENTS:		SIZE A DWG. NO. 1021-6	
DRAWING IS NOT TO SCALE				SHEET 1 OF 1