

REFEERENCE SEASTROM WORKMANSHIP STD. 8.4.1.W2

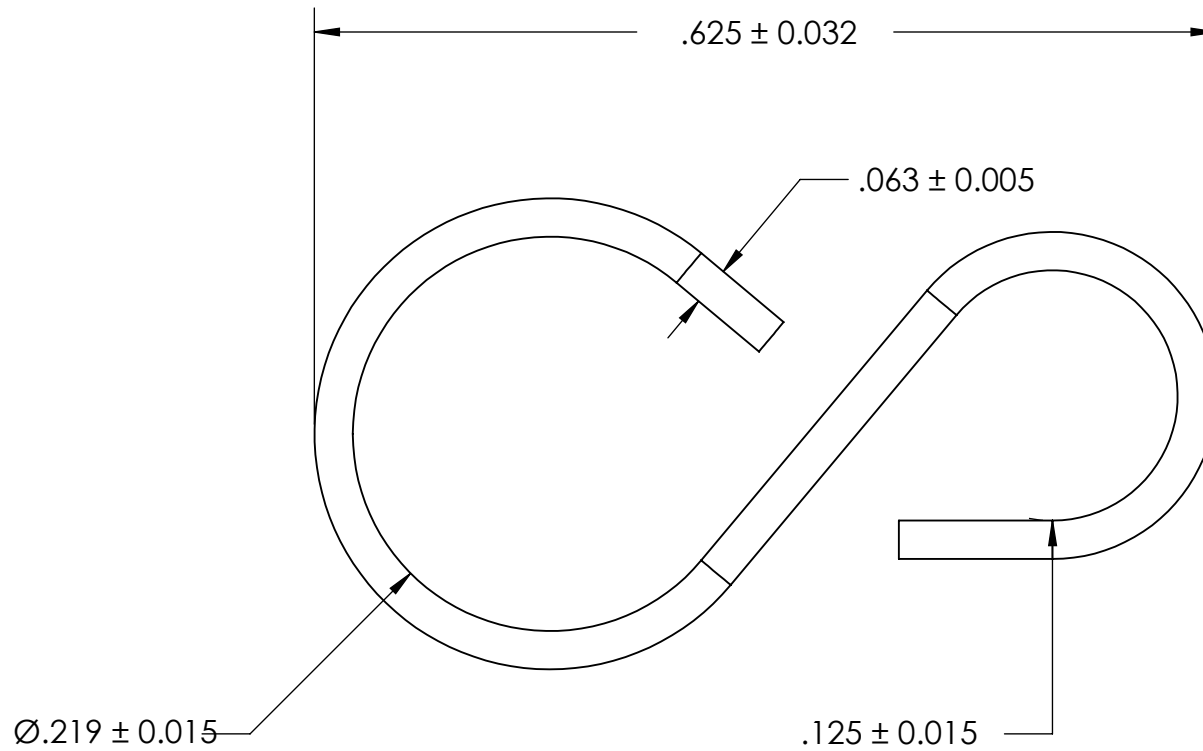

NOTES

1. CADMIUM PLATE PER AMS QQ-P-416 TYPE I CLASS 2

2. DIMENSIONS APPLY BEFORE PLATING

PROPRIETARY AND CONFIDENTIAL
 THE INFORMATION CONTAINED IN THIS DRAWING IS THE SOLE PROPERTY OF SEASTROM MANUFACTURING. ANY REPRODUCTION IN PART OR AS A WHOLE WITHOUT THE WRITTEN PERMISSION OF SEASTROM MANUFACTURING IS PROHIBITED.

DIMENSIONS ARE IN INCHES TOLERANCES: FRACTIONAL $\pm 1/32$ ANGULAR: MACH $\pm 1/2$ Deg TWO PLACE DECIMAL $\pm .01$ THREE PLACE DECIMAL $\pm .005$	NAME	DATE	SEASTROM MFG	
	DRAWN			
	CHECKED		TAGS AND MARKER BANDS	
	ENG APPR.			
	MFG APPR.			
MATERIAL COLD ROLLED STEEL	Q.A.		SIZE A	DWG. NO. 1000
FINISH SEE NOTE 1	COMMENTS:		REV. -	
DRAWING IS NOT TO SCALE			SHEET 1 OF 1	